

# REKLUSE



## REKLUSE MOTOR SPORTS

---

The z-Start Pro Clutch

## INSTALLATION GUIDE

**07-08 BMW650 X Models**

191-601  
Manual Revision: 121207

©2002 Rekluse Motor Sports  
Rekluse Motor Sports, Inc.  
110 E. 43rd Street  
Boise, Idaho 83714  
208-426-0659  
[support@rekluse.com](mailto:support@rekluse.com)

# TABLE OF CONTENTS

<b>z-START PRO CROSS-SECTION VIEW</b>	<b>3</b>
<b>INCLUDED PARTS</b>	<b>3</b>
<b>REQUIRED TOOLS</b>	<b>3</b>
<b>BIKE PREPARATION AND DISASSEMBLY</b>	<b>4</b>
<b>INSTALLING THE z-START PRO CENTER CLUTCH</b>	<b>5</b>
<b>INSTALLING THE CLUTCH PACK</b>	<b>5</b>
<b>INSTALLING THE Z-START PRO CLUTCH</b>	<b>6</b>
<b>DETERMINE THE INSTALLED GAP OF THE Z-START PRO CLUTCH</b>	<b>9</b>
<b>SETTING CLUTCH CABLE SLACK</b>	<b>11</b>
<b>APPENDIX A – CENTER CLUTCH REMOVAL TIP SHEET</b>	<b>12</b>

## Z-START PRO CROSS-SECTION VIEW

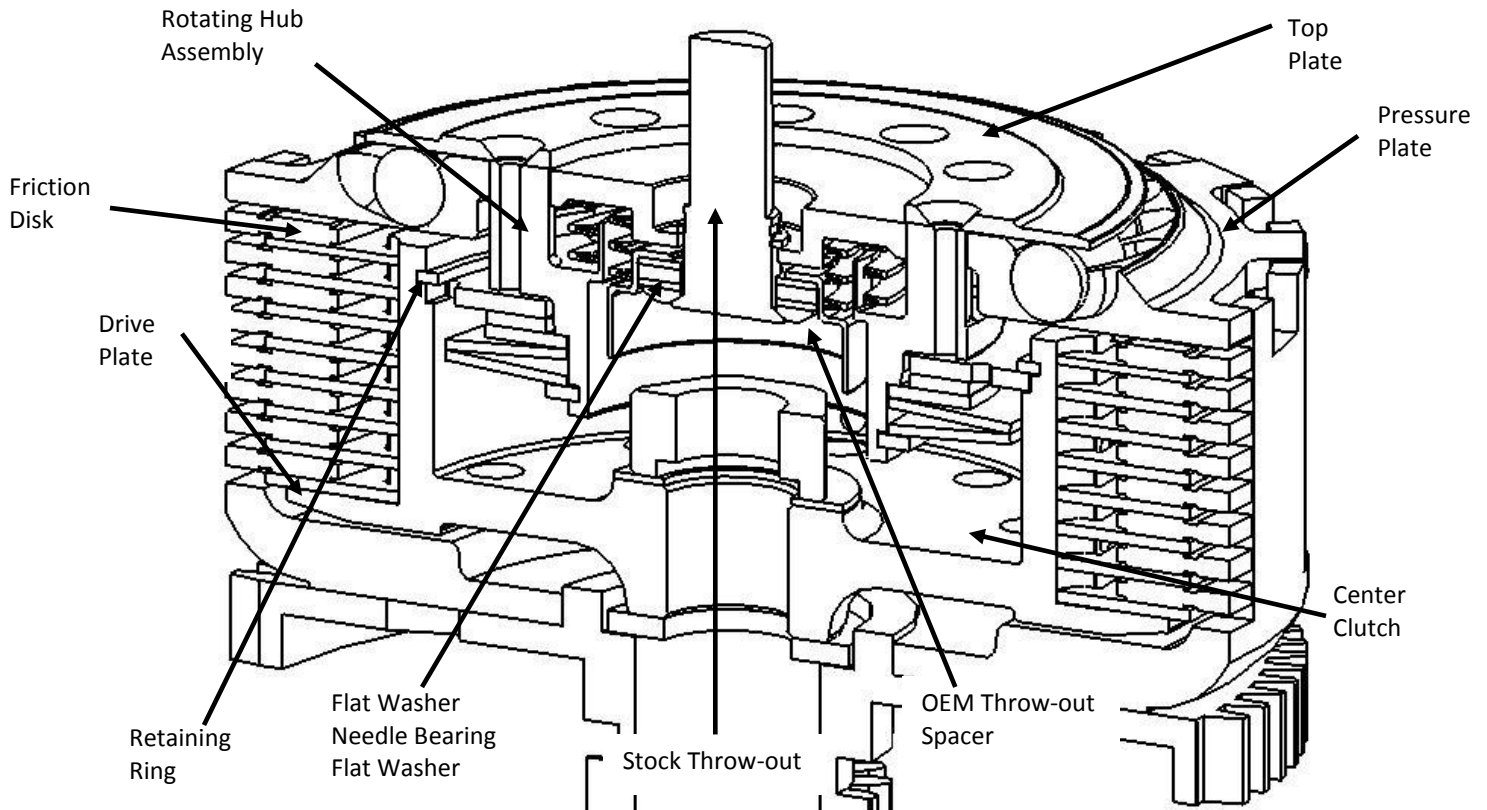

## INCLUDED PARTS

### Item

- Top Plate
- Pressure Plate
- Rekluse Center Clutch
- Retaining Ring
- (1) RMS Friction Disks
- (8) RMS Measured Drive Plates
- (1) RMS 0.065" Drive Plate (Adjustment Plate)
- Rotating Hub Assembly
- Rekluse Spring Carrier

### Item

- Needle Bearing
- (2) Flat Thrust Washers
- (27) 7/16" Chrome Steel Ball Bearings
- (18) 7/16" Tungsten Carbide Ball Bearings
- (10) M4x12 Torx Head Screws
- C200M4 Wave Spring
- C150M4 Wave Spring
- T-20 Torx Bit
- Blue Loctite 243
- Rekluse Wire Gauges

## REQUIRED TOOLS

- 8mm socket
- 10mm socket
- 27mm or 30mm socket (for center clutch nut)
- T-20 Torx bit (supplied)
- Impact Wrench
- Snap ring pliers

## BIKE PREPARATION AND DISASSEMBLY

1. Disconnect the clutch cable at the clutch perch.
2. Lay bike on right side. **CAUTION:** fuel may drain; to prevent fire hazard, place a suitable container beneath bike to catch fuel.
3. Remove shift lever.
4. Remove clutch actuator arm.
5. Remove clutch cover.
6. Remove bolts and springs from OEM pressure plate.
7. Remove OEM pressure plate.
8. Remove OEM clutch throw-out retaining ring with snap ring pliers and set aside. Remove OEM clutch throw-out from the pressure plate and set aside. The snap ring and throw-out will be re-installed.
9. Remove the clutch pack (friction disks and drive plates).
10. Remove the OEM center clutch hub following the steps outlined in the vehicle manufacturer's service manual. Retain the OEM Lock washer.  
  
Also, see the center clutch removal tip sheet (Appendix A) for further assistance.
11. Retain OEM thrust washer located between OEM clutch basket and OEM center clutch hub.

**NOTE: thrust washer may be stuck to bottom of OEM center clutch hub.**

## INSTALLING THE Z-START PRO CENTER CLUTCH

12. Install the Rekluse Center Clutch with the OEM thrust washer behind it on top of the basket.
13. Install the OEM lock washer on top of the Rekluse Center Clutch.
14. Install center clutch nut and torque to the specified torque value found in the manufacturer's service manual.
15. Bend washer up against a face of the center clutch nut.



## INSTALLING THE CLUTCH PACK

16. The 8 Rekluse steel drive plates packaged with the Rekluse Center Clutch come pre-measured and are the 8 steel drive plates you will start with.
17. You will use the Rekluse friction disk with the 7 OEM friction disks. Install 1 Rekluse steel drive plate onto the Rekluse Center Clutch.

As you install the rest of the clutch pack, place the Rekluse friction disk somewhere near the middle of the pack. **See chart for specific model configuration.**

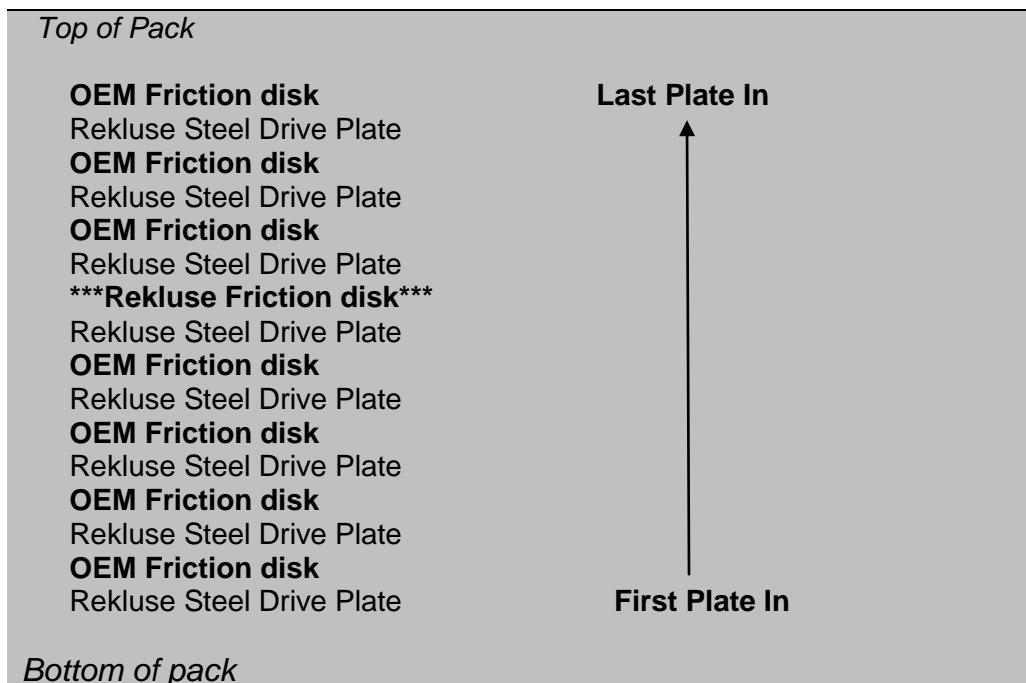

## INSTALLING THE Z-START PRO CLUTCH

18. Place lower assembly into Rekluse center clutch hub. You must align the three cut-outs in the lower assembly with the corresponding tabs in the center clutch. Note: some models only have two cut-outs.

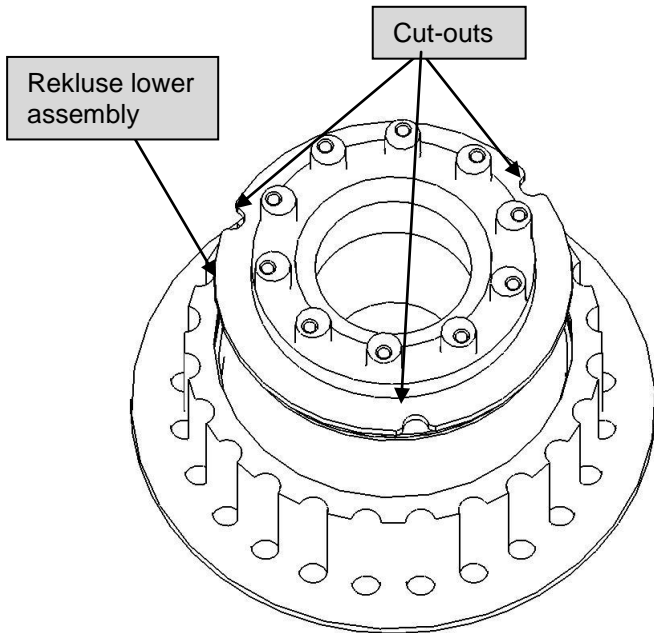

19. Using a pair of mechanics gloves (the edges of the ring can be sharp and may cut you), install the retaining ring into the Rekluse Center Clutch ring groove.

You must ensure the retaining ring is snapped into the groove. Start the square end of the ring and thread the ring into the groove as shown, ensuring that the scalloped end of the ring is clockwise in relation to the square end.

**WARNING: Scalloped end of ring MUST be oriented as shown above-right.**

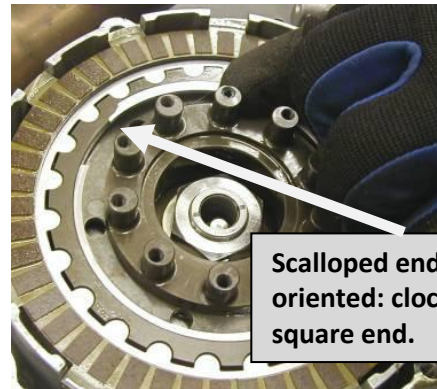

Scalloped end of ring correctly oriented: clockwise in relation to square end.

Threading retaining ring into groove

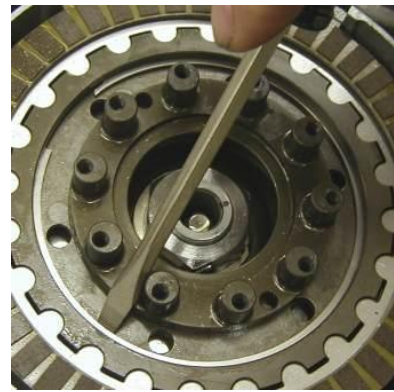

Use a screwdriver to ensure the ring is seated by sliding along the ring's inner diameter.

20. Remove the OEM Belleville washer from OEM throw-out, leaving the OEM spacer.

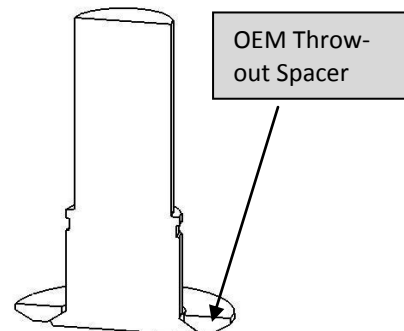

21. Install 1 of the flat thrust washers followed by the needle bearing followed by the remaining flat thrust washer on top of the OEM clutch throw-out and spacer.

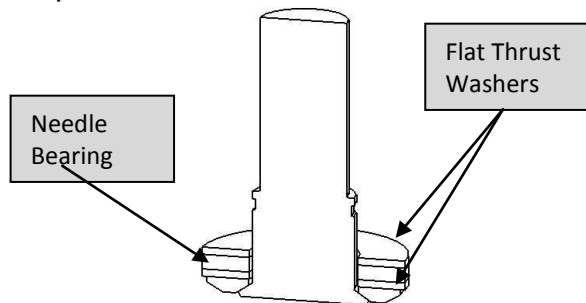

22. Install the Rekluse spring carrier followed by the C150 Wave Spring.

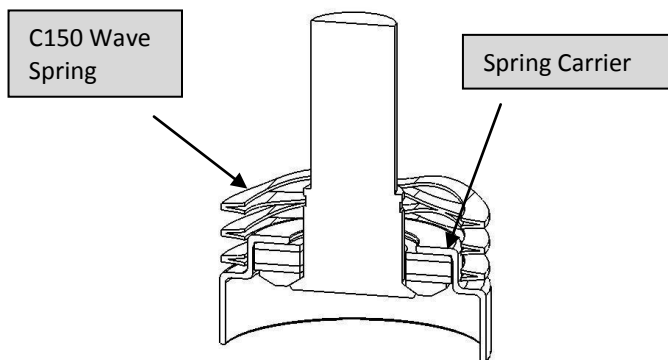

23. Guide the Rekluse pressure plate over the throw-out and secure with the OEM retaining ring. You will need to compress spring to access ring groove.

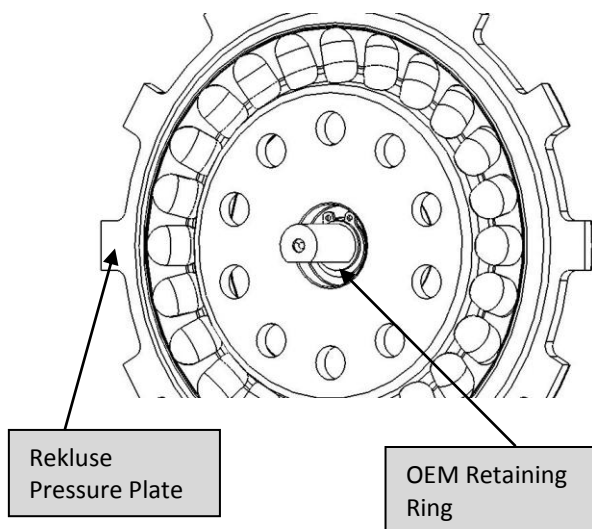

24. Install the C200 wave spring on top of rotating hub into the locating pocket.

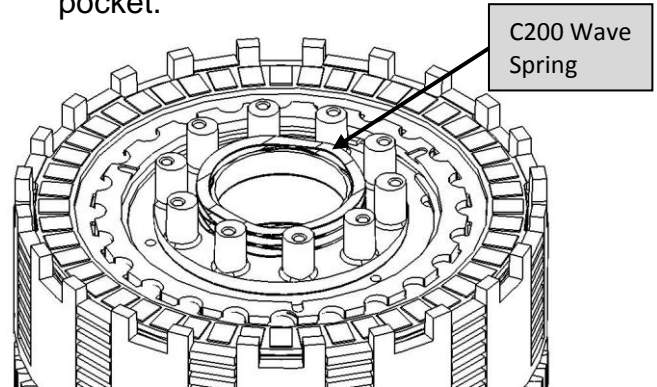

25. Place a small amount of oil into the ball grooves of the Rekluse Pressure Plate.

26. Away from the bike, install the 18 tungsten carbide (TC) balls and 9 of the steel balls into the pressure plate ball grooves. **The TC balls must be evenly spaced amongst the steel balls.**

**Pattern:** 6 TC balls followed by 3 steel balls. Repeat until all grooves are full.

27. Place the Rekluse pressure plate, with balls, over the lower assembly. Line the 10 holes in the pressure plate up with the 10 rotating hub posts. Also, line the outer tabs of the pressure plate up with the basket slots.

**IMPORTANT:** The basket has 2 sets of slots, make sure you index the Rekluse pressure plate tabs into the main/deep slots.

- 28.** Push and hold the pressure plate down, overcoming the wave springs, so the 10 rotating hub posts index into the 10 pressure plate holes and line up with the 10 countersunk holes in the top plate.

**Note:** An extra set of hands is helpful.

Pressure plate tabs located in main "deep" basket slots.

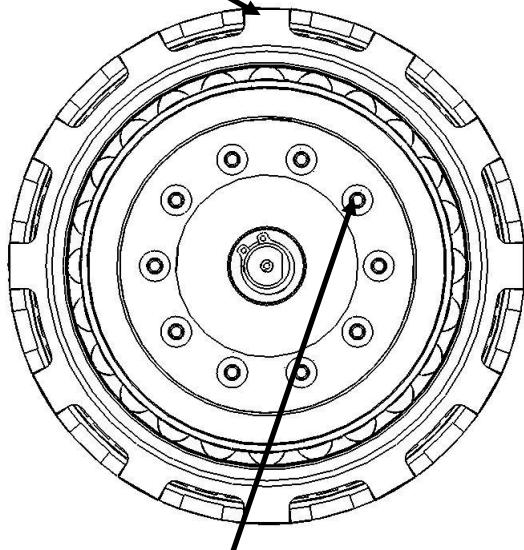

Rotating hub posts indexed into pressure plate holes and lined up with top plate holes.

- 29.** While holding down the pressure plate so it is indexed with the basket and 10 rotating hub posts properly, place the Rekluse top plate over the Rekluse pressure plate and thread in 2 torx head screws 180° across from one another. Lightly tighten the 2 screws to secure the Rekluse top plate.



## DETERMINE THE INSTALLED GAP OF THE Z-START PRO CLUTCH

**Note:** Installed gap is measured using two no-go wire gauges. Therefore, if gauges **do not** slide between Rekluse pressure plate and **the pads** of the top friction disk, your **installed gap is correct**.

If gauges **do** slide between the Rekluse pressure plate and **the pads** of the top friction disk, you **need to adjust your installed gap** according to step 32.

30. Verify that top-most friction disk moves up and down freely between the Pressure Plate and top-most steel drive plate by pulling up and down on top-most friction disk. If no “float” exists, top-most **steel drive plate** has become disoriented during previous step and needs to be re-installed.
31. Attempt to slide the shorter legs of the 2 included 0.050” *no-go* wire gauges **between the Rekluse pressure plate and the friction pads** of the top friction disk 180° apart.

If clutch pack wear exists, gauges will slide in with slight resistance. Do not force the gauges in, if the gauges **do not** slide in smoothly then the Installed Gap is good and you can move on to Step 33.

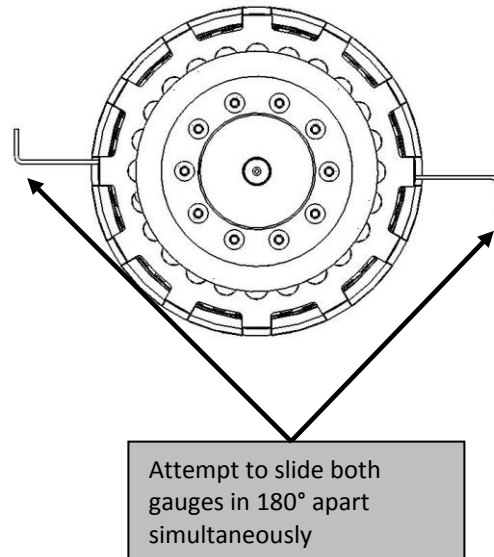
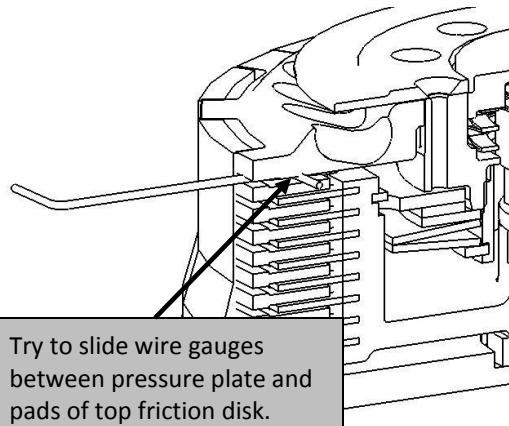
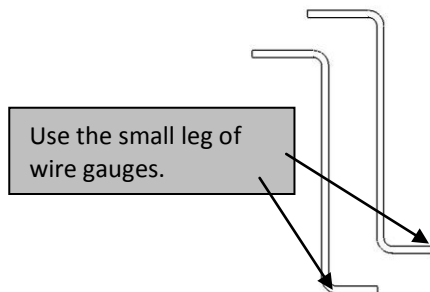

**NOTE:** The gauges need to slide in past the “relief” point on the underside of the pressure plate to get an accurate measurement.

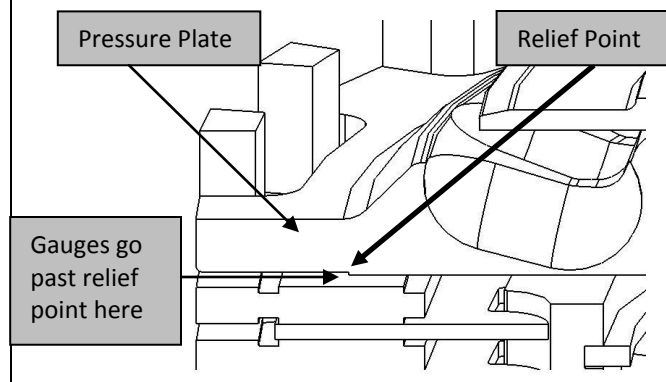

32. If the wire gauges slide in **smoothly**, the clutch pack needs adjustment. Swap the thick Rekluse adjustment drive plate for the top drive plate. Repeat step 31.

**Note:** The adjustment drive plate is .065". Once this drive plate has been used, and the clutch wears enough so the wire gauges slide in again, the friction disks need to be replaced.

33. Install the remaining 8 torx head screws using blue Loctite 243 and torque to 14 in-lbs (1.58 Nm).
34. Remove the 2 screws originally installed without Loctite, apply Loctite and torque.
35. Align the teeth of the clutch throwout at 2 o'clock. **See image below.**

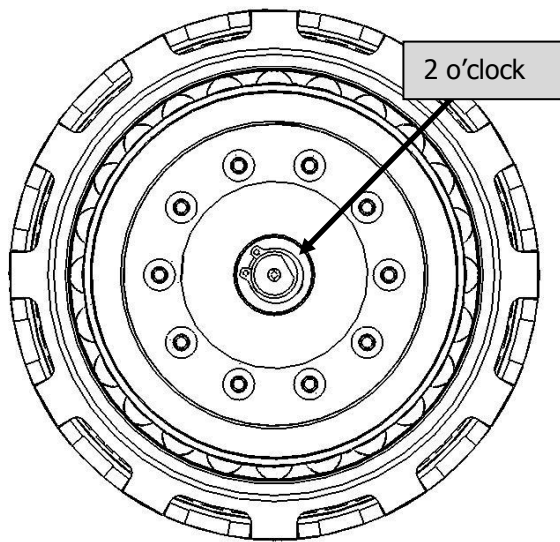

36. Re-install clutch cover.

37. Align clutch actuator arm so it points slightly past top dead center (i.e. toward rear of bike). Rotate forward and connect clutch cable. **See photo below.**

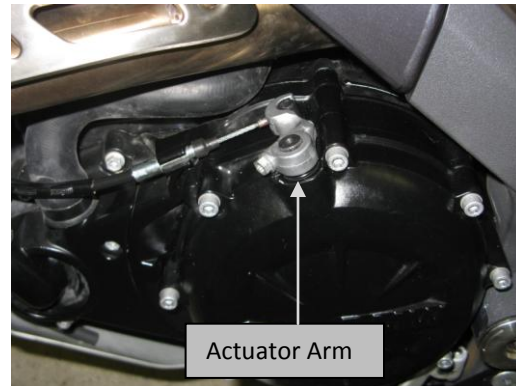

38. Re-install shift lever.
39. Re-install exhaust gasket if it was removed during step 5.
40. Stand the bike upright and reconnect the clutch cable to the lever.

**IMPORTANT: SEE NEXT PAGE OF INSTRUCTIONS FOR PROPER CABLE SLACK SETTING**

41. Adjust the cable slack for the z-Start Pro (SEE NEXT PAGE).

## SETTING CLUTCH CABLE SLACK

**IMPORTANT:** Cable slack adjustment is **critical**. The cable slack must be adjusted properly and maintained frequently. Failure to do so will result in clutch failure.

Adjusting cable slack is different with a z-Start Pro Clutch installed. Cable slack adjustment requires starting the motor in neutral and revving to a minimum of 4500 RPMs (approximately ½-throttle) while checking for lever free play. **There must be clutch lever free play while holding a minimum of 4500 RPMs.**

**If there is not enough cable slack, the clutch will slip excessively causing the clutch to fail.**

Too much cable slack reduces the ability to disengage the clutch at higher RPMs.

**WARNING:** *Ensure the bike is in neutral* or it could lunge forward unexpectedly when revving the engine.

**Place the bike into neutral and start the engine.** While holding a minimum of 4500 RPMs, check for 1/2" (1cm) of play at the end of the clutch lever before you feel significant resistance. Adjust cable slack accordingly using stock cable slack adjuster(s).

In other words, when revving the engine, clutch lever free play should feel like stock.

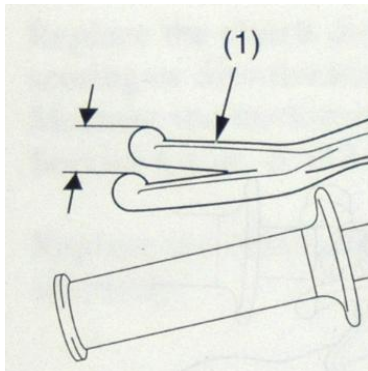

**Tip:** Use one finger with light pull when checking for lever free play. This will make it easier to distinguish between the light resistance of the lever return spring and the significant resistance felt when disengaging the Rekluse pressure plate.

**Note:** Be sure to review the included Break-in and Maintenance Guide for clutch pack wear adjustments.

**WARNING:** After a 20 minute break-in period, the clutch plates will seat in and you must re-measure the Installed Gap to guarantee the Installed Gap is within the prescribed range—make drive plate adjustments if necessary. Clutch break-in re-measurement of the Installed Gap is necessary whenever new clutch plates are installed.

Refer to the “Safety Warnings” and “Break-in Tuning and Maintenance Guide” before operating the z-Start Pro clutch.

## APPENDIX A – CENTER CLUTCH REMOVAL TIP SHEET

The following covers 3 methods for removing the OEM center clutch from your motorcycle or ATV. **At no time should you ever pry against the standoffs of the OEM center clutch because they are easily broken.**

**Note:** If your bike has an external tab lock washer, use a flat blade screwdriver to pry the tabs away from the nut. Next use a hammer and punch to lightly tap the tabs flat.

**1. Pneumatic or electric impact gun:**

Place the bike in gear and remove the nut

**2. Clutch Holding Tool:**

Example: Motion Pro # 08-0008

Use the clutch holding tool to hold the center clutch while using a wrench to remove the center clutch nut.

**3. Holding the Rear Brake:**

Place the bike in 4<sup>th</sup> or 5<sup>th</sup> gear (a higher gear gives you more mechanical advantage). Apply the rear brake firmly and hold firmly while using a wrench to remove the center clutch nut. A second set of hands is helpful.