

REKLUSE



REKLUSE MOTOR SPORTS

The z-Start Pro Clutch

INSTALLATION GUIDE

KTM 950/990 LC8 Engine

191-631

Manual Revision: 080108

©2007 Rekluse Motor Sports
Rekluse Motor Sports, Inc.
110 E. 43rd Street
Boise, Idaho 83714
208-426-0659
support@rekluse.com

TABLE OF CONTENTS

z-START PRO CROSS-SECTION VIEW	3
INCLUDED PARTS	3
REQUIRED TOOLS	3
BIKE PREPARATION AND DISASSEMBLY	4
INSTALLING THE z-START PRO CENTER CLUTCH	5
INSTALLING THE CLUTCH PACK	6
INSTALLING THE z-START PRO CLUTCH	8
DETERMINE THE INSTALLED GAP OF THE z-START PRO CLUTCH	10
APPENDIX A – CENTER CLUTCH REMOVAL TIP SHEET	12

Z-START PRO CROSS-SECTION VIEW

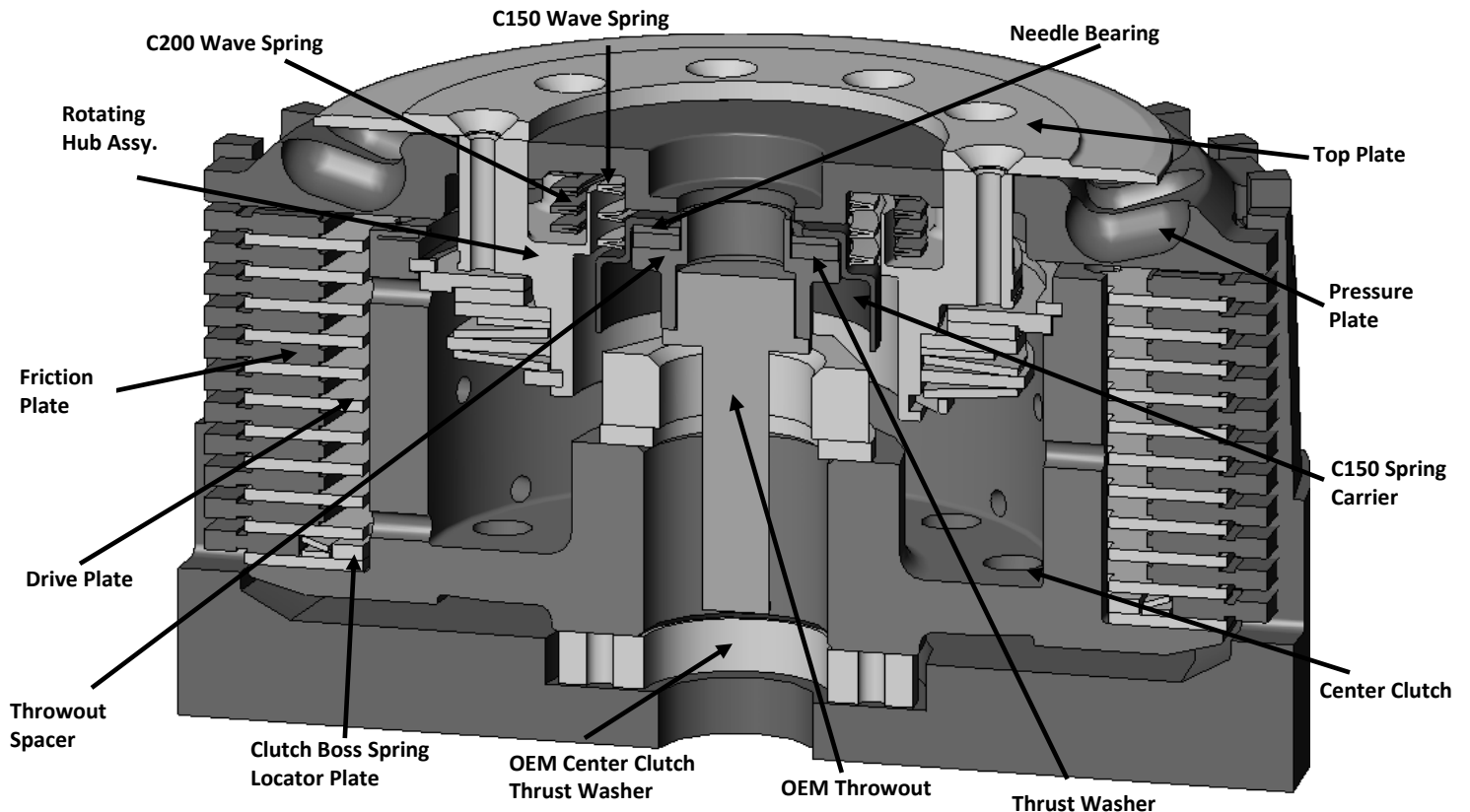

INCLUDED PARTS

Item

- Top Plate
- Pressure Plate
- Rekluse Center Clutch
- Retaining Ring
- (11) 0.060 RMS Drive Plates
- (1) RMS 0.078" Drive Plate (Adjustment Plate)
- (1) RMS 0.048" Drive Plate (Adjustment Plate)
- Clutch Boss Spring Locator Plate
- C150 Spring Carrier

Item

- Rotating Hub Assembly
- Rekluse Throw-out Spacer
- (27) 7/16" Chrome Steel Ball Bearings
- (10) M4x12 Torx Head Screws
- C200 Wave Springs (see setup sheet)
- C150 L4 Wave Spring
- T-20 Torx Bit
- Blue Loctite 243
- Rekluse Wire Gauges
- Thrust Washer
- Thrust Bearing

REQUIRED TOOLS

- 8mm socket
- 10mm socket
- 31mm socket (for center clutch nut)
- T-20 Torx bit (supplied)
- Impact Wrench

BIKE PREPARATION AND DISASSEMBLY

1. Shut off fuel at petcock. Lay bike over onto so that the left side of handlebar is supported approximately 2 ft. off ground (a typical motorcycle center stand works well for this). **CAUTION:** fuel may drain from carburetor; place a suitable container beneath bike to catch fuel to prevent fire hazard.
2. Remove rear brake lever.
3. Remove clutch access cover.
4. Remove the bolt, dampening plate, and dampener from the inside of the clutch cover.

WARNING: If these items are not removed, damage to the clutch will occur.

5. Remove the bolts holding the 6 springs and the OEM pressure plate and remove the springs and pressure plate.
6. Remove the OEM center clutch via the center clutch nut. The OEM throw-out does not need to be removed.

NOTE: Center clutch nut is directional. Pay attention to its orientation when you remove it; chamfered side faces up.

7. Remove the clutch pack (friction disks and drive plates). Separate the friction disks from the pack as they will be re-installed.
8. Retain the clutch boss spring located at the bottom of the clutch pack on the center clutch base. The clutch boss spring consists of 2 metal rings, 1 flat seat and one Belleville spring. The clutch boss spring will be re-installed.
9. Retain OEM thrust washer located between OEM clutch basket and OEM center clutch hub.

NOTE: thrust washer may be stuck to bottom of OEM center clutch hub.

INSTALLING THE Z-START PRO CENTER CLUTCH

10. Install the Rekluse Center Clutch with the OEM thrust washer behind it on top of the basket.
11. Secure the Rekluse center clutch with the OEM nut and lock washer. Ensure that chamfered side of nut faces up.
12. Put bike into 5th gear. Re-attach and apply rear brake.
13. Torque the center clutch nut to the specified torque found in the manufacturer's service manual.
14. Remove rear brake.

INSTALLING THE CLUTCH PACK

15. Install 1 Rekluse .060" steel drive plate onto the Rekluse Center Clutch.
16. Place the clutch boss spring locator plate on top of the bottom steel plate.
17. Install clutch boss spring seat and clutch boss spring.
18. Install **OEM narrow friction plate** on top of Rekluse .060" steel drive plate.

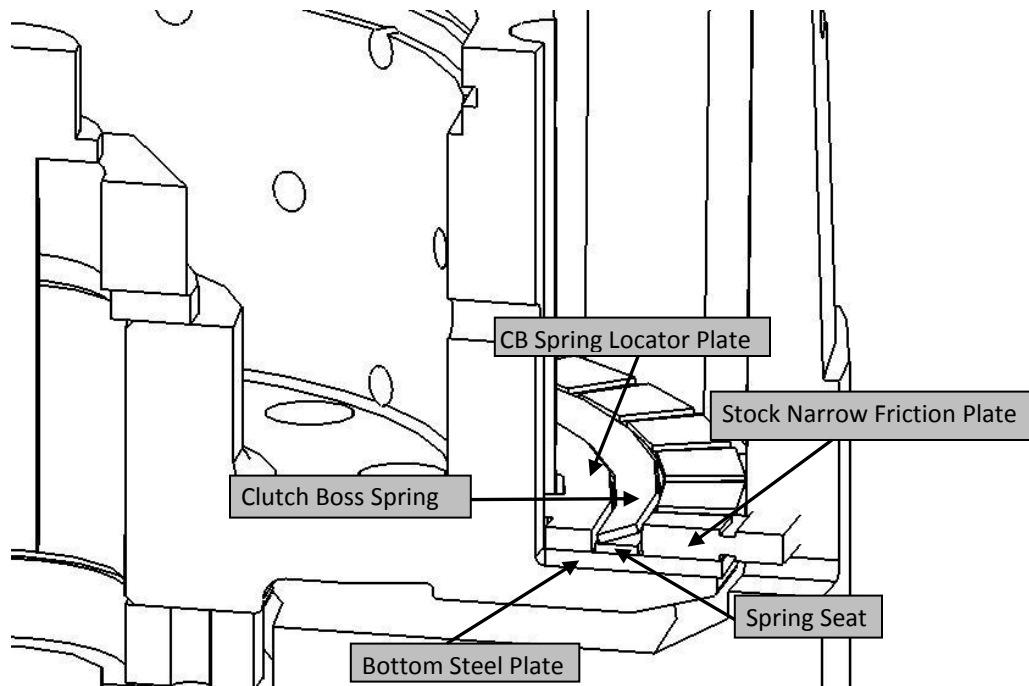

19. Alternate Rekluse .060" steel drive plates with OEM friction plates. **Install Rekluse .048" steel drive plate as second steel drive plate from top.** See chart on following page.

Top of Pack

- OEM friction plate
- Rekluse .060" steel drive plate
- OEM friction plate
- Rekluse .048" steel drive plate**
- OEM friction plate
- Rekluse .060" steel drive plate
- OEM friction plate
- Rekluse .060" steel drive plate
- OEM friction plate
- Rekluse .060" steel drive plate
- OEM friction plate
- Rekluse .060" steel drive plate
- OEM friction plate
- Rekluse .060" steel drive plate
- OEM friction plate
- Rekluse .060" steel drive plate
- OEM friction plate
- Rekluse .060" steel drive plate
- OEM friction plate
- Rekluse .060" steel drive plate
- OEM narrow friction plate**
- Rekluse .060" steel drive plate

Last plate in

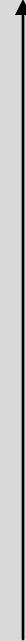

First plate in

Bottom of Pack

Note: Top drive plate MUST be a .060" or .078" Rekluse steel drive plate.

INSTALLING THE Z-START PRO CLUTCH

20. Place lower assembly into Rekluse center clutch hub. You must align the cut-outs in the lower assembly with the corresponding tabs in the center clutch. Note: some models only have two cut-outs.

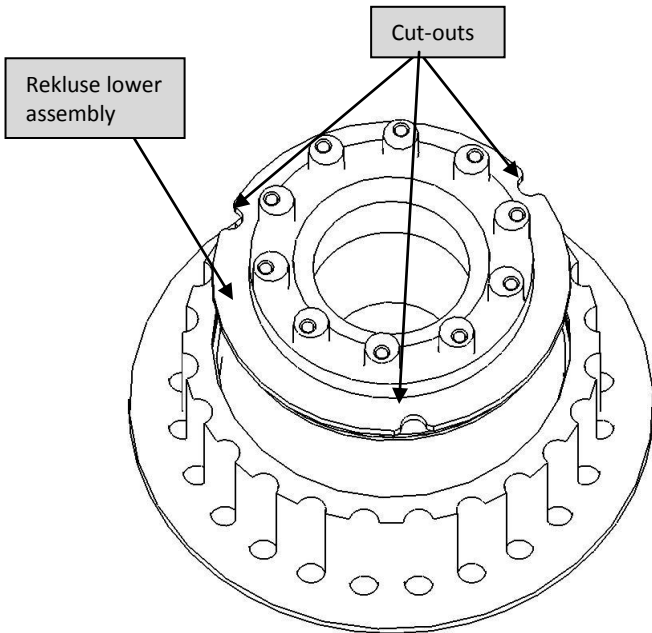

21. Using a pair of mechanics gloves (the edges of the ring can be sharp and may cut you), install the retaining ring into the Rekluse Center Clutch ring groove.

You must ensure the retaining ring is snapped into the groove. Start the square end of the ring and thread the ring into the groove as shown, ensuring that the scalloped end of the ring is clockwise in relation to the square end.

WARNING: Scalloped end of ring MUST be oriented as shown above-right.

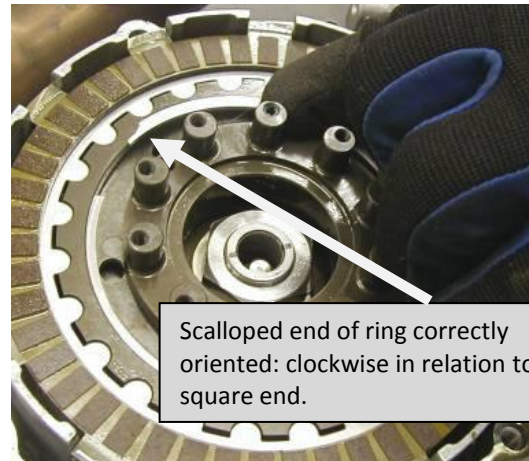

Threading retaining ring into groove



Use a screwdriver to ensure the ring is seated by sliding along the ring's inner diameter.

- 22.** Install the Rekluse throw-out spacer with the needle bearing and thrust washer on top of it.

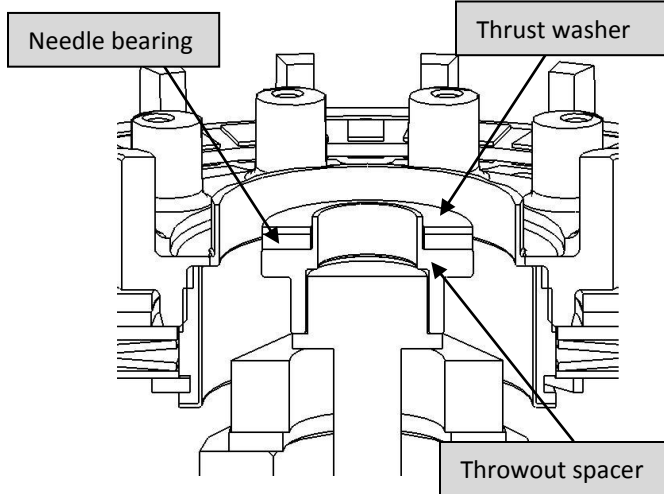

- 23.** Install the C150 Spring Carrier over the thrust washer on top of the Rekluse throw-out spacer followed by the C150L4 Wave spring.

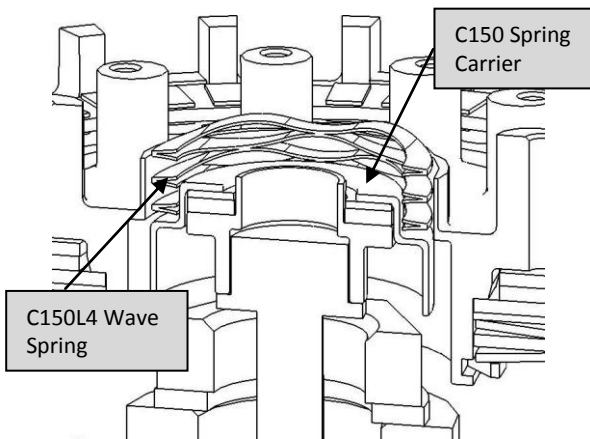

- 24.** Read the Setup and Tuning Guide to determine desired spring setting.

- 25.** Install the C200 wave spring (chosen based on your desired setup from Tuning Chart) on top of rotating hub into the locating pocket.

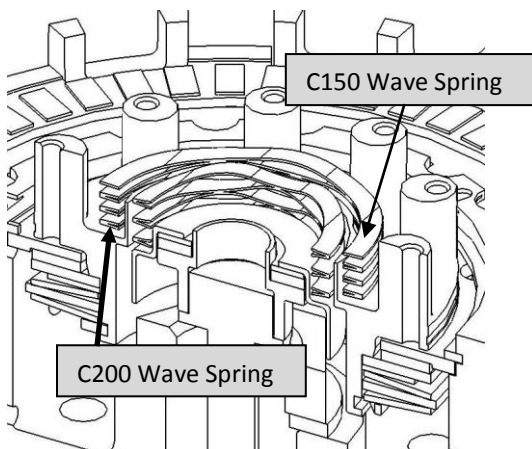

- 26.** Place a small amount of oil into the ball grooves of the Rekluse Pressure Plate.

- 27.** Away from the bike, install the steel balls into the pressure plate ball grooves.

- 28.** Place the Rekluse pressure plate, with balls, over the lower assembly. Line the 10 holes in the pressure plate up with the 10 rotating hub posts. Also, line the outer tabs of the pressure plate up with the basket slots. Index the top of the throw-out inside the center hole of the Rekluse Pressure Plate.

- 29.** Push and hold the pressure plate down, overcoming the wave spring and hydraulic clutch pressure, so the 10 rotating hub posts index into the 10 pressure plate holes.

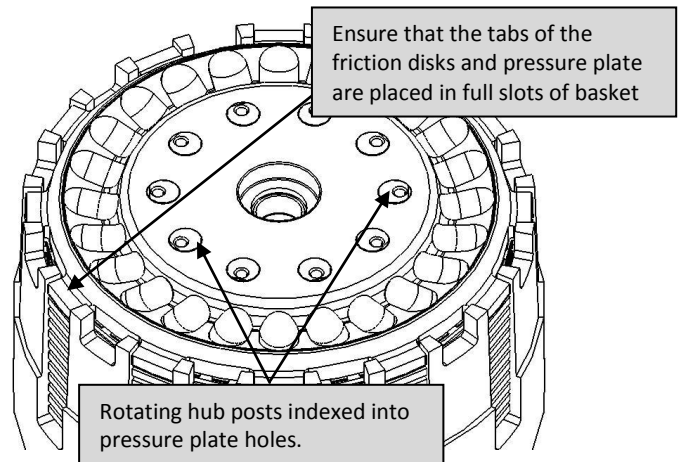

- 30.** While holding down the pressure plate so it is indexed with the basket and 10 rotating hub posts properly, place the Rekluse top plate over the Rekluse pressure plate and thread in 2 torx head screws 180° across from one another. Lightly tighten the 2 screws to secure the Rekluse top plate.



DETERMINE THE INSTALLED GAP OF THE Z-START PRO CLUTCH

Note: Installed gap is measured using two no-go wire gauges. Therefore, if gauges **do not** slide between Rekluse pressure plate and **the pads** of the top friction disk, your **installed gap is correct**.

If gauges **do** slide between the Rekluse pressure plate and **the pads** of the top friction disk, you **need to adjust your installed gap** according to step 33.

31. Verify that top-most friction disk moves up and down freely between the Pressure Plate and top-most steel drive plate by pulling up and down on top-most friction disk. If no “float” exists, top-most **steel drive plate** has become disoriented during previous step and needs to be re-installed.
32. Attempt to slide the shorter legs of the 2 included 0.050” *no-go* wire gauges **between the Rekluse pressure plate and the friction pads** of the top friction disk 180° apart.

If clutch pack wear exists, gauges will slide in with slight resistance. Do not force the gauges in, if the gauges **do not** slide in smoothly then the Installed Gap is good and you can move on to Step 34.

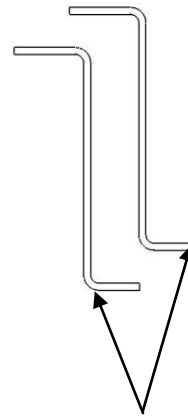

Use the small leg of wire gauges.

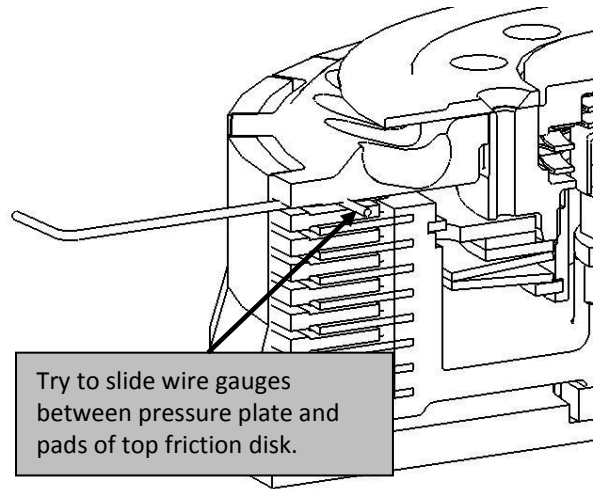

Try to slide wire gauges between pressure plate and pads of top friction disk.

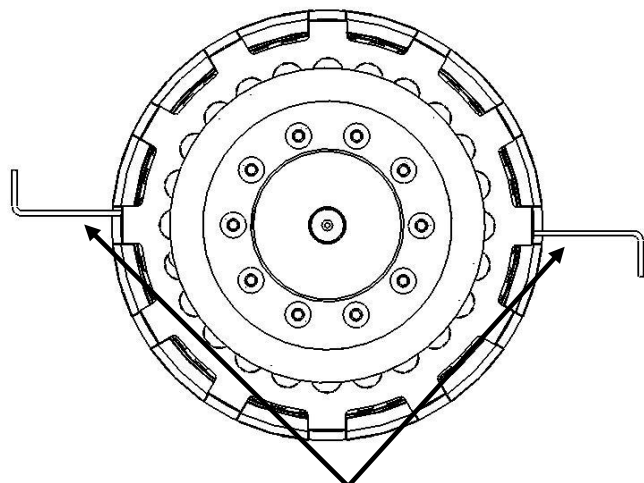

Attempt to slide both gauges in 180° apart simultaneously

33. If the wire gauges slide in smoothly, the clutch pack needs adjustment.

1st Adjustment: replace the .048" Rekluse steel drive plate with the remaining .060" Rekluse steel drive plate. Repeat step 32.

2nd Adjustment: (if gauges slide in again following 1st adjustment): replace the top .060" Rekluse steel drive plate with the .078" Rekluse steel drive plate. Repeat step 32.

Note: If .078" Rekluse steel drive plate is used it **MUST be top steel drive plate.**

34. Install the remaining 8 torx head screws using blue Loctite 243 and torque to 25 in-lbs.
35. Remove the 2 screws originally installed without Loctite, apply Loctite and torque.
36. Re-install the clutch cover. Lightly tighten all of the cover bolts before full torque is applied, or you may break the cover.

Note: Be sure to review the included Break-in and Maintenance Guide for clutch pack wear adjustments.

WARNING: After a 20 minute break-in period, the clutch plates will seat in and you must re-measure the Installed Gap to guarantee the Installed Gap is within the prescribed range—make drive plate adjustments if necessary. Clutch break-in re-measurement of the Installed Gap is necessary whenever new clutch plates are installed.

37. Re-install rear brake.
38. Refer to the "Safety Warnings" and "Break-in Tuning and Maintenance Guide" before operating the z-Start Pro clutch.
39. You may need to drain charcoal canister of fuel due to bike being laid over onto left side. Refer to KTM Service Manual for procedure.

APPENDIX A – CENTER CLUTCH REMOVAL TIP SHEET

The following covers 3 methods for removing the OEM center clutch from your motorcycle or ATV. **At no time should you ever pry against the standoffs of the OEM center clutch because they are easily broken.**

Note: If your bike has an external tab lock washer, use a flat blade screwdriver to pry the tabs away from the nut. Next use a hammer and punch to lightly tap the tabs flat.

- 1. Pneumatic or electric impact gun:**
Place the bike in gear and remove the nut
- 2. Clutch Holding Tool:**
Example: Motion Pro # 08-0008
Use the clutch holding tool to hold the center clutch while using a wrench to remove the center clutch nut.
- 3. Holding the Rear Brake:**
Place the bike in 4th or 5th gear (a higher gear gives you more mechanical advantage). Apply the rear brake firmly and hold firmly while using a wrench to remove the center clutch nut. A second set of hands is helpful.