

# REKLUSE



## REKLUSE MOTOR SPORTS

---

The z-Start Pro Clutch

### INSTALLATION GUIDE

**KTM RFS 03-07**

**Husaberg**

**Polaris 450/525 Outlaw**

**KTM 450/525 XC ATV**

191-833

Manual Revision: 032508

©2002 Rekluse Motor Sports  
Rekluse Motor Sports, Inc.  
110 E. 43rd Street  
Boise, Idaho 83714  
208-426-0659  
support@rekluse.com

# TABLE OF CONTENTS

<b>z-START PRO CROSS-SECTION VIEW</b>	<b>3</b>
<b>INCLUDED PARTS</b>	<b>3</b>
<b>REQUIRED TOOLS</b>	<b>3</b>
<b>BIKE PREPARATION AND DISASSEMBLY</b>	<b>4</b>
<b>INSTALLING THE z-START PRO CENTER CLUTCH</b>	<b>4</b>
<b>INSTALLING THE CLUTCH PACK</b>	<b>5</b>
<b>INSTALLING THE z-START PRO CLUTCH</b>	<b>6</b>
<b>DETERMINE THE INSTALLED GAP OF THE z-START PRO CLUTCH</b>	<b>9</b>
<b>APPENDIX A – CENTER CLUTCH REMOVAL TIP SHEET</b>	<b>11</b>

## Z-START PRO CROSS-SECTION VIEW

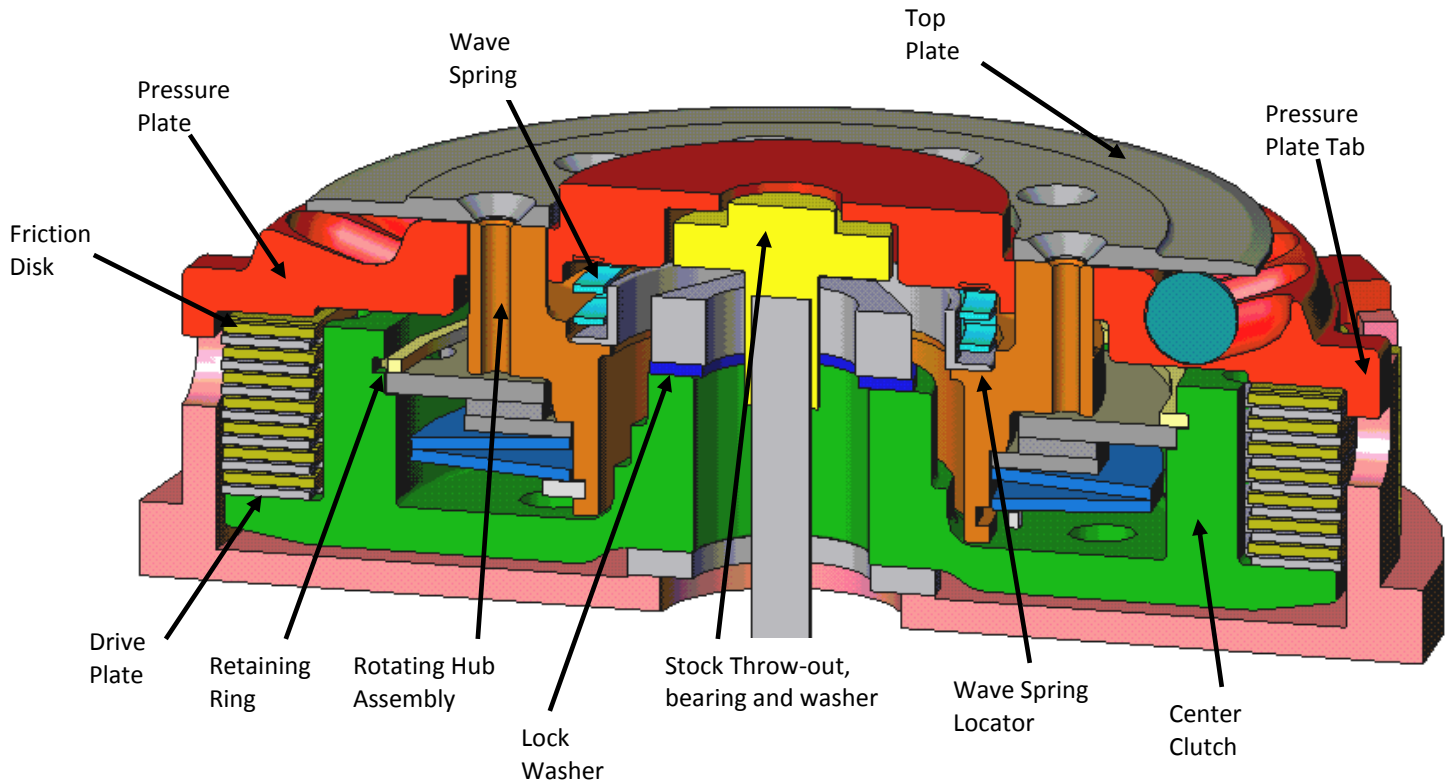

## INCLUDED PARTS

### Item

- Top Plate
- Pressure Plate
- Rekluse Center Clutch
- Retaining Ring
- (7) RMS Measured Drive Plates
- (1) RMS 0.060" Drive Plate (Adjustment Plate)
- Rotating Hub Assembly
- External Tab Lock Washer
- Throw-out Spacer ('03-'05 Models Only)

### Item

- (27) 7/16" Chrome Steel Ball Bearings
- (10) M4x12 Torx Head Screws
- Wave Spring Locator
- Wave Springs (See Tuning Chart)
- T-20 Torx Bit
- Blue Loctite 243
- Rekluse Wire Gauges

## REQUIRED TOOLS

- 8mm socket
- 10mm socket
- 27mm or 30mm socket (for center clutch nut)

- T-20 Torx bit (supplied)
- Impact Wrench
- 2 Sets of Feeler Gauges (optional)

## BIKE PREPARATION AND DISASSEMBLY

**NOTE:** '02-'03 models come with .070" friction plates stock. Owners of these models must verify thickness of their friction plates; if they **are** .070" they will need to be replaced with .078" ('04 and newer) friction plates.

1. Shut off fuel at petcock. Lay bike on left side. **CAUTION:** fuel may drain from carburetor; place a suitable container beneath bike to catch fuel to prevent fire hazard.

### **Outlaw/KTM ATV Owners:**

Lean the quad against a fixed stationary object at a suitable angle so that the quad is stable—the further you lean it over the easier the install will go. Place blocks or stands under front and rear wheels to prevent the quad from falling. When Quad is tipped on its side be prepared to catch the excess gas and oil in a suitable container to prevent a fire hazard.

2. Remove clutch cover.
3. Remove bolts and springs from OEM pressure plate.

**WARNING:** Once pressure plate and springs are removed, there will no longer be pressure against the hydraulic system. **DO NOT** pull in clutch lever until z-Start Pro is completely installed or slave cylinder housing will be damaged and will need to be replaced.

4. Remove OEM pressure plate.
5. Remove OEM clutch throw out and set aside.
6. Remove the clutch pack (7 friction disks and 8 drive plates) and set aside.
7. Remove the OEM center clutch hub following the steps outlined in the vehicle manufacturer's service manual.
8. Retain OEM thrust washer located between OEM clutch basket and OEM center clutch hub.

**NOTE:** thrust washer may be adhered to bottom of OEM center clutch hub.

## INSTALLING THE Z-START PRO CENTER CLUTCH

9. Install the Rekluse Center Clutch with the OEM thrust washer behind it on top of the basket.
10. Install the included Rekluse external tab lock washer over the main-shaft on top of the Rekluse center clutch.
11. Bend middle tab down aligned with flat side of the Rekluse Center Clutch.
12. Torque the center clutch nut to the specified torque found in the manufacturer's service manual.
13. Using a pair of adjustable pliers, bend remaining two tabs of external tab washer up against the nut securing it.



## INSTALLING THE CLUTCH PACK

14. The 7 Rekluse steel drive plates packaged with the Rekluse Center Clutch come pre-measured and are the 7 steel drive plates you will start with.

Install 1 Rekluse steel drive plate onto the Rekluse Center Clutch.

**Note:** A Rekluse steel drive plate must be the first clutch plate installed.

15. Install the stock friction disks with a Rekluse steel drive plate between each one.  
**See following chart:**

**Note:** With the z-Start Pro you use 7 Friction disks and 7 Rekluse Drive Plates.

**NOTE:** '03 ONLY, if you have .070" friction plates, we recommend upgrading to KTM OEM .078" friction plates. Alternatively, you can stack the .060" fine wear steel adjustment plate on top of the .040" steel plate (this stacks two steel plates together) to achieve installed gap.

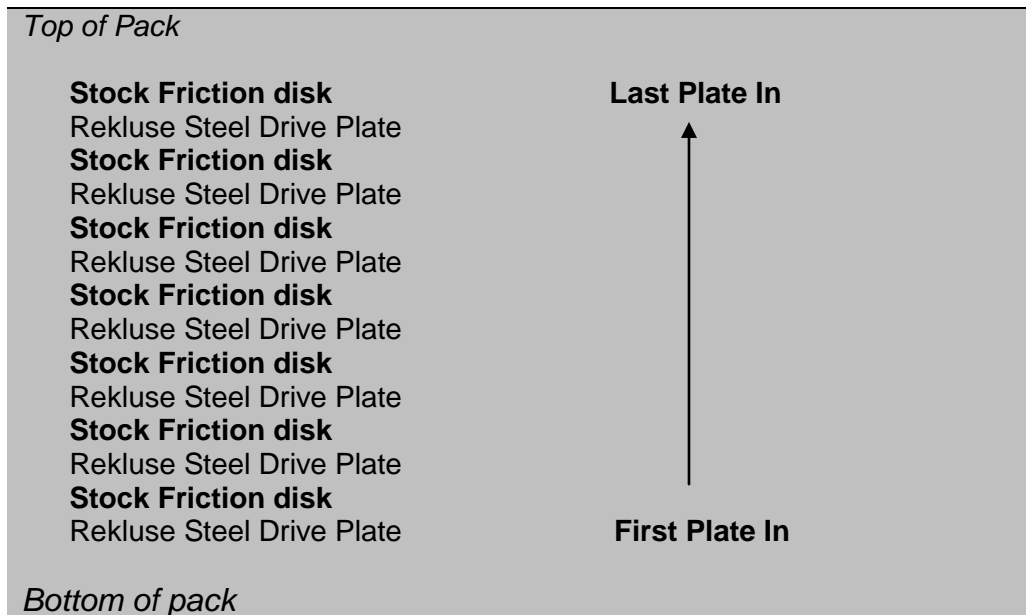

## INSTALLING THE Z-START PRO CLUTCH

16. Place lower assembly into Rekluse center clutch hub. You must align the three cut-outs in the lower assembly with the corresponding tabs in the center clutch.

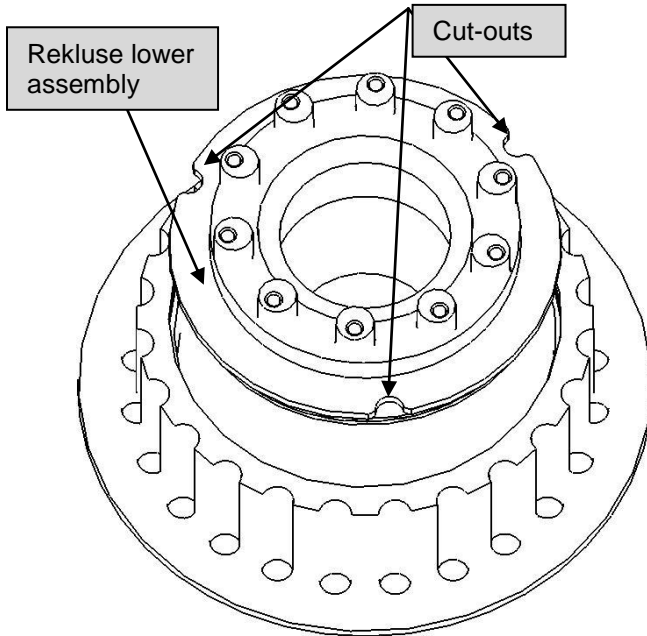

17. Using a pair of mechanics gloves (the edges of the ring can be sharp and may cut you), install the retaining ring into the Rekluse Center Clutch ring groove.

You must ensure the retaining ring is snapped into the groove. Start the square end of the ring and thread the ring into the groove as shown, ensuring that the scalloped end of the ring is clockwise in relation to the square end.

**WARNING: Scalloped end of ring MUST be oriented as shown above-right.**

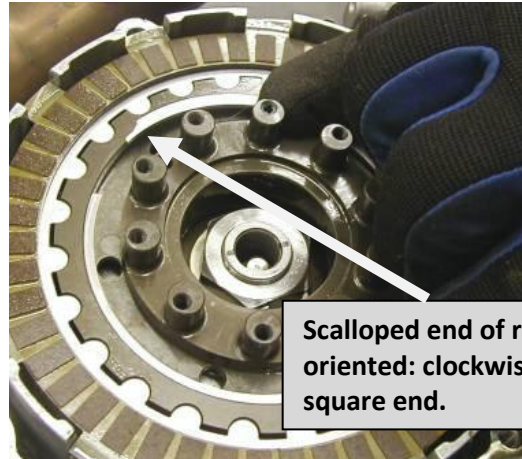

Scalloped end of ring correctly oriented: clockwise in relation to square end.

Threading retaining ring into groove



Use a screwdriver to ensure the ring is seated by sliding along the ring's inner diameter.

**WARNING: It is CRITICAL that the retaining ring is fully seated using a screwdriver, or clutch damage WILL occur.**

18. Install OEM clutch throw out.

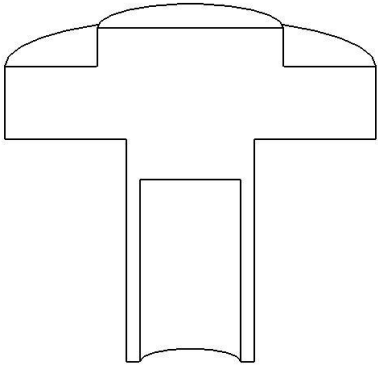

19. '03-'05 RFS and All Husaberg Owners Only: Install the Rekluse throw-out spacer on top of the throw-out.

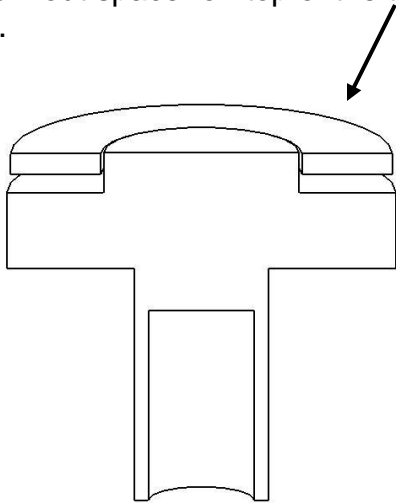

**Warning:** The Rekluse Throw-out Spacer is not used on '06-'07 KTM Models. **DO NOT INSTALL IT ON THOSE MODELS.**

20. Read the Setup and Tuning Guide to determine the desired spring setting.

21. Install the C200 wave spring (chosen based on your desired setup from the tuning sheet for your bike) on top of rotating hub into the locating pocket.

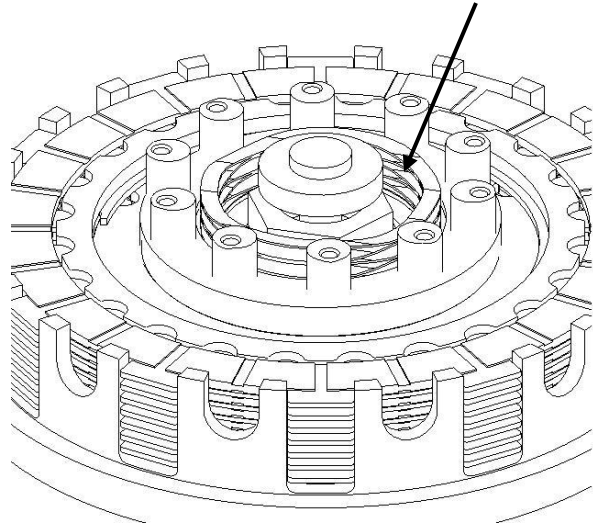

22. Place a small amount of oil into the ball grooves of the Rekluse Pressure Plate.

23. Away from the bike, install the 7/16" steel balls into the pressure plate ball grooves. There are 27 slots, if you chose a 24 ball configuration, leave an empty slot after every 8<sup>th</sup> ball—empty ball grooves must be evenly spaced.

**Husaberg Owners:** See Tuning Chart for special ball configuration instructions.

**Outlaw/KTM ATV Owners:** See Tuning Chart for special ball configuration instructions.

24. Place the Rekluse pressure plate, with balls, over the lower assembly.

- Line the 10 holes in the pressure plate up with the 10 rotating hub posts.
- Line the outer tabs of the pressure plate up with the **half-moon basket slots**.

**NOTE:** The half-moon slots are the basket slots that do not contain the friction disk tabs. The half-moon slots are where the Rekluse pressure plate tabs must index.

25. Push and hold the pressure plate down, overcoming the wave spring and hydraulic clutch pressure, so the 10 rotating hub posts index into the 10 pressure plate holes.

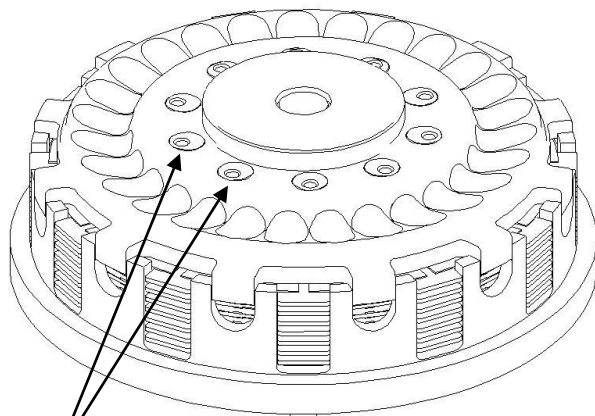

Rotating hub posts indexed into pressure plate holes.

26. While holding down the pressure plate so it is indexed with the basket and 10 rotating hub posts properly, place the Rekluse top plate over the Rekluse pressure plate and thread in 2 of the torx head screws 180° across from one another. Lightly tighten the 2 screws.

Tabs of Pressure Plate indexed into proper basket slots.

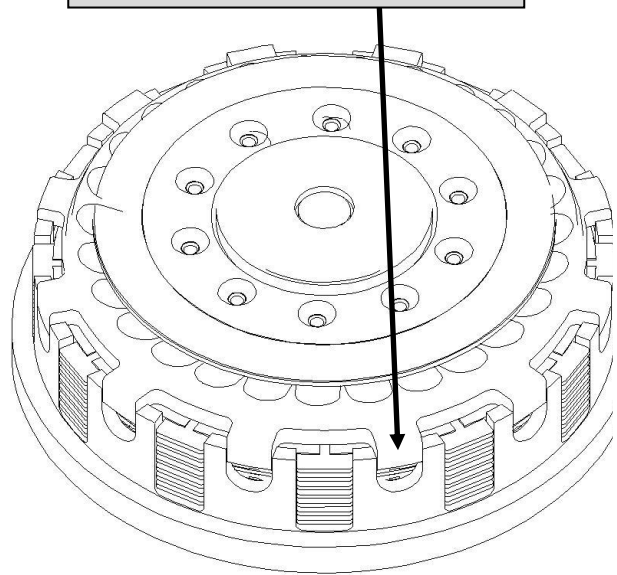

## DETERMINE THE INSTALLED GAP OF THE Z-START PRO CLUTCH

27. Verify that top-most friction disk moves up and down freely between the Pressure Plate and top-most steel drive plate by pulling up and down on top-most friction disk. If no “float” exists, top-most **steel drive plate** has become disoriented during previous step and needs to be re-installed.

28. Attempt to slide the shorter legs of the 2 included 0.050” *no-go* wire gauges under the Rekluse Pressure Plate and the top-most friction plate, 180° apart.

If clutch pack wear exists, gauges will slide in with slight resistance. Do not force the gauges in, if the gauges **do not** slide in smoothly then the Installed Gap is good and you can move on to Step 30.

**Note:** no-go wire gauges will only slide in if the friction disks have wear.

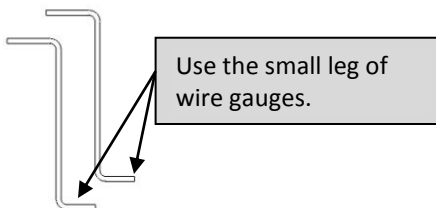

29. If the wire gauges can be slid up and over the pads smoothly, the clutch pack needs adjustment. Swap the thick .060” Rekluse drive plate for the top drive plate. Repeat step 28.

30. Install the remaining 8 torx head screws using blue Loctite 243 and torque to 25 in-lbs.

**Note:** It is easiest to insert the wires in the space between friction disk pads, and then slide them **over the top of the pads and up in between the pads and the Rekluse Pressure Plate**.

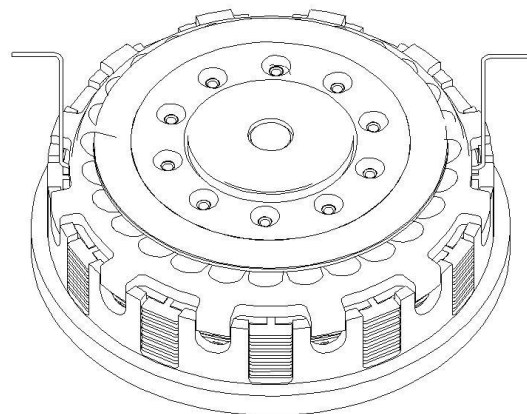
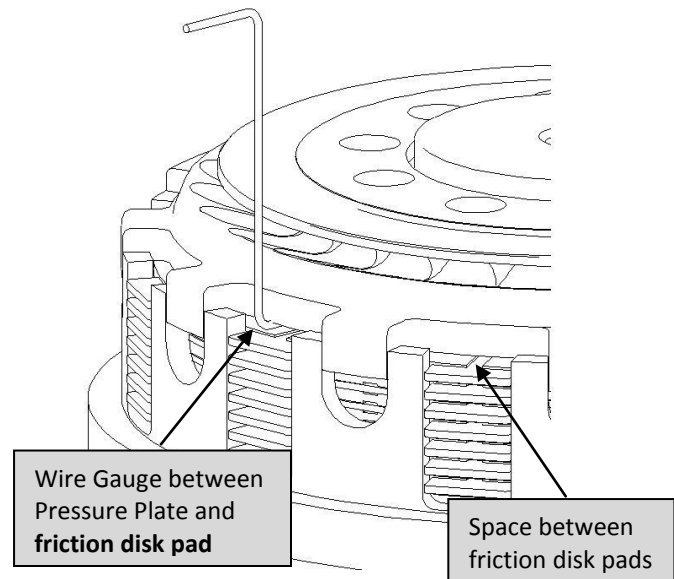

**Note:** A .060” drive plate is included with z-Start Pro Clutch Kit to tighten the Installed Gap. Once the .060” drive plate has been used, and the clutch wears enough so the wire gauges slide in again, the friction disks need to be replaced.

31. Remove the 2 screws originally installed without Loctite, apply Loctite and torque.
32. Re-install the clutch cover with the OEM Gasket.

**Note:** Be sure to review the included Break-in and Maintenance Guide for clutch pack wear adjustments.

**WARNING:** After a 20 minute break-in period, the clutch plates will seat in and you must re-measure the Installed Gap to guarantee the Installed Gap is within the prescribed range—make drive plate adjustments if necessary. Clutch break-in re-measurement of the Installed Gap is necessary whenever new clutch plates are installed.

Refer to the “Safety Warnings” and “Break-in Tuning and Maintenance Guide” before operating the z-Start Pro clutch.

## APPENDIX A – CENTER CLUTCH REMOVAL TIP SHEET

The following covers 3 methods for removing the OEM center clutch from your machine. **At no time should you ever pry against the standoffs of the OEM center clutch because they are easily broken.**

**Note:** If your bike has an external tab lock washer, use a flat blade screwdriver to pry the tabs away from the nut. Next use a hammer and punch to lightly tap the tabs flat.

**1. Pneumatic or electric impact gun:**

Place the bike in gear and remove the nut

**2. Clutch Holding Tool:**

Example: Motion Pro # 08-0008

Use the clutch holding tool to hold the center clutch while using a wrench to remove the center clutch nut.

**3. Holding the Rear Brake:**

Place the bike in 4<sup>th</sup> or 5<sup>th</sup> gear (a higher gear gives you more mechanical advantage). Apply the rear brake firmly and hold firmly while using a wrench to remove the center clutch nut. A second set of hands is helpful.