

# REKLUSE



## REKLUSE MOTOR SPORTS

---

The z-Start Pro Clutch

### INSTALLATION GUIDE

**KTM 125, 144, 200 2-Stroke**

**KTM 250, 300 2-Stroke**

**KTM 250 SXF, XC, XC-W**

**KTM 400 XC-W**

**KTM 450, 505 SXF, XC-F**

**KTM 450, 530 XCR-W, EXC-R**

**Husaberg 450, 570 FE**

191-836

Manual Revision: 101708

©2002 Rekluse Motor Sports  
Rekluse Motor Sports, Inc.  
110 E. 43rd Street  
Boise, Idaho 83714  
208-426-0659  
support@rekluse.com

# TABLE OF CONTENTS

<b>z-START PRO CROSS-SECTION VIEW</b>	<b>3</b>
<b>INCLUDED PARTS</b>	<b>3</b>
<b>REQUIRED TOOLS</b>	<b>3</b>
<b>BIKE PREPARATION AND DISASSEMBLY</b>	<b>4</b>
<b>CLUTCH BASKET INSPECTION</b>	<b>4</b>
<b>INSTALLING THE z-START PRO CENTER CLUTCH</b>	<b>6</b>
<b>INSTALLING THE CLUTCH PACK</b>	<b>6</b>
<b>INSTALLING THE z-START PRO CLUTCH</b>	<b>8</b>
<b>DETERMINE THE INSTALLED GAP OF THE z-START PRO CLUTCH</b>	<b>11</b>
<b>APPENDIX A – CENTER CLUTCH REMOVAL TIP SHEET</b>	<b>13</b>

## Z-START PRO CROSS-SECTION VIEW

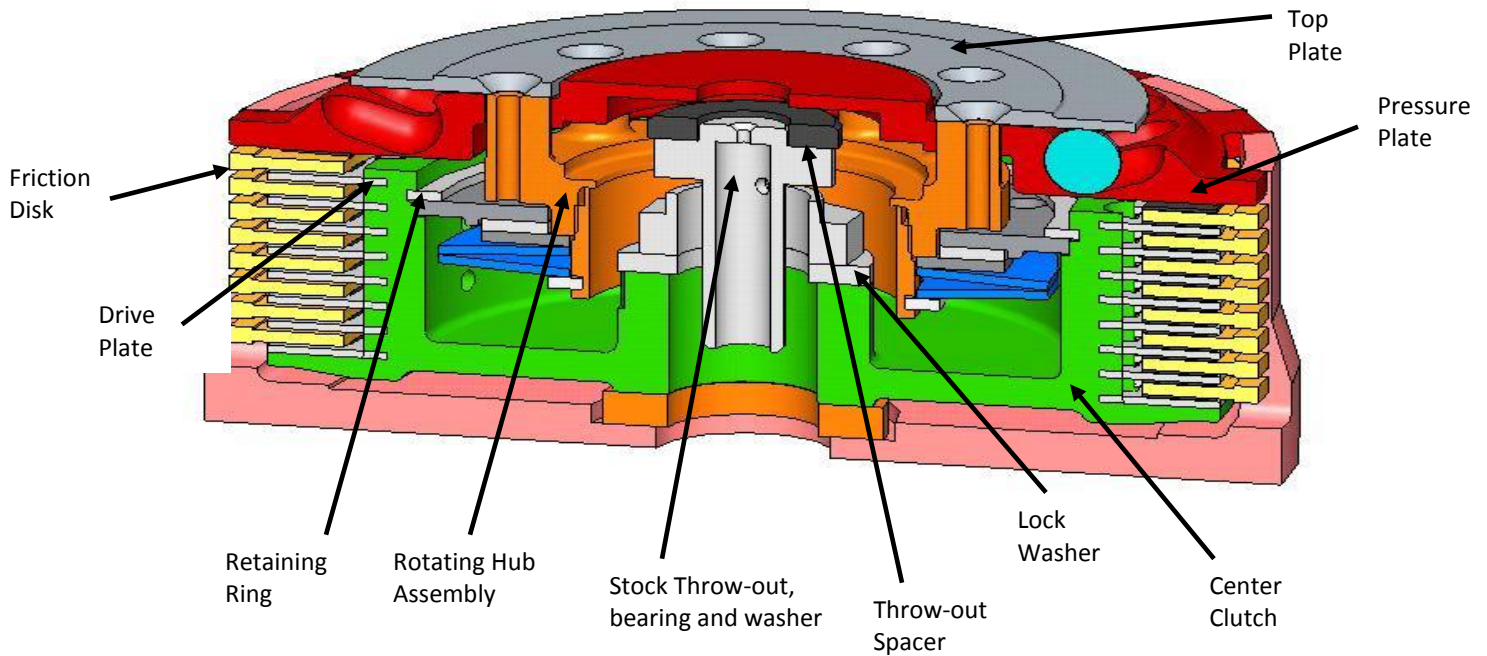

## INCLUDED PARTS

### Item

- Top Plate
- Pressure Plate
- Rekluse Center Clutch
- Retaining Ring
- (8) RMS Measured Drive Plates (7 for 125/200)
- (1) RMS 0.065" Drive Plate (Adjustment Plate) **or**
- (1) RMS 0.060" Drive Plate (Adjustment Plate – 125/200 2-stroke, 250 4-stroke)
- Rotating Hub Assembly
- External Tab Lock Washer
- Rekluse Throw-out Spacer

### Item

- (27) 7/16" Chrome Steel Ball Bearings (250/300 2-stroke) **or**
- (30) 3/8" Chrome Steel Ball Bearings (125/200 2-stroke, 250 4-stroke)
- (10) M4x12 Torx Head Screws
- Wave Springs (see setup sheet)
- T-20 Torx Bit
- Blue Loctite 243
- Rekluse Clutch Cover Gasket
- Rekluse Wire Gauges
- Anti-squeal Kit

## REQUIRED TOOLS

- 8mm socket
- 10mm socket
- 27mm or 30mm socket (for center clutch nut)
- T-20 Torx bit (supplied)
- Impact Wrench

## BIKE PREPARATION AND DISASSEMBLY

1. Before you begin, read these instructions carefully and check to ensure all parts are present.
2. Shut off fuel at petcock. Lay bike on left side. **CAUTION:** fuel may drain from carburetor; place a suitable container beneath bike to catch fuel to prevent fire hazard.
3. Remove clutch cover.
4. Remove bolts and springs from OEM pressure plate.

**WARNING:** Once pressure plate and springs are removed, there will no longer be pressure against the hydraulic system. DO NOT pull in clutch lever until z-Start Pro is completely installed or slave cylinder housing will be damaged and will need to be replaced.

5. Remove OEM pressure plate.
6. Remove OEM clutch throw out and set aside. It will be re-installed.
7. Remove the clutch pack (friction disks and drive plates). Separate the friction disks from the pack as they will be re-installed.
8. Remove the OEM center clutch hub following the steps outlined in the vehicle manufacturer's service manual. Also, see the center clutch removal tip sheet for further assistance.
9. Retain OEM thrust washer located between OEM clutch basket and OEM center clutch hub.

**NOTE:** thrust washer may be stuck to bottom of OEM center clutch hub.

# CLUTCH BASKET INSPECTION

**NOTE:** The following outlines Clutch Basket Dampener Failure. Some Clutch baskets will last a season, and some last only hours. If the dampeners go unchecked clutch damage will result. After inspecting basket, continue with the z-Start Pro installation.

## Clutch Basket Dampener Operation

Most OEM Clutches use elastomer dampeners to protect the clutch from shock loading applied to the basket by the drive train and/or engine during normal operating conditions. The dampeners are located between the clutch basket body and the ring gear. The dampeners take up the slack between the ring gear and clutch basket so that under normal loading they rotate as one. Under extreme loading the dampeners provide a cushion so the ring gear and basket can float independently and keep shock loads from being transferred to the clutch.

As the dampeners wear, the system gains slack and shock loads start getting transferred to the clutch. This creates a hammering effect between the clutch basket and ring gear. The hammering transfers to the clutch plates and causes the plates to wear away at the clutch basket and center clutch hub. If the dampeners continue to go unchecked, the hammering progresses until the clutch fails.

## Checking Your Clutch Basket for Dampener Failure

Prior to installing the z-Start Pro, it is recommended that you check the condition of your Clutch Basket and Center Clutch Hub.

An indication of failing clutch basket dampeners is grooving or notching of the Clutch Basket Ears—where the tabs of the friction discs index into the clutch basket. See the following picture. Another indication of failing dampeners is notching of the center clutch hub where the steel drive plates index to it.

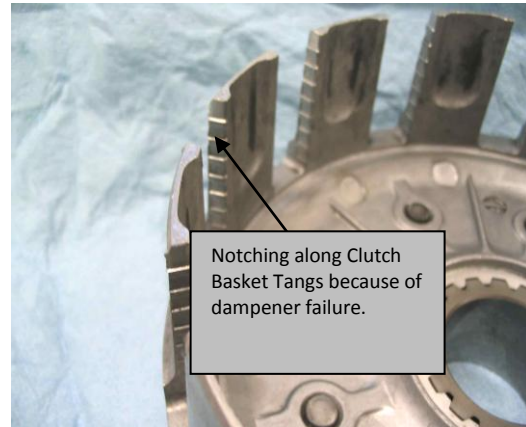

## Maintaining Clutch Basket Dampeners

Unfortunately the OEM clutch basket does not provide a means to maintain the dampeners. After the dampeners wear out, the clutch basket must be replaced. The choice is either an OEM clutch basket, or an aftermarket basket. The advantage of an aftermarket basket is that the dampeners are serviceable. Rekluse offers aftermarket clutch baskets specially designed for greater performance with the z-Start Pro.

**NOTE:** Except for CRF450R/X, Rekluse Clutch Baskets do not include elastomer dampeners. Call for further information.

**WARNING:** Installing the z-Start into a worn clutch basket can greatly reduce clutch performance, and damage the z-Start Pressure Plate.

## INSTALLING THE Z-START PRO CENTER CLUTCH

9. Install 3 supplied x-rings into the Rekluse Center Clutch as shown below, leaving one empty pocket between each x-ring. Ensure that the x-ring is fully seated into the pocket. There are six pockets: 3 will have x-rings and 3 will not. **Note:** see anti-squeal kit manual for further information.

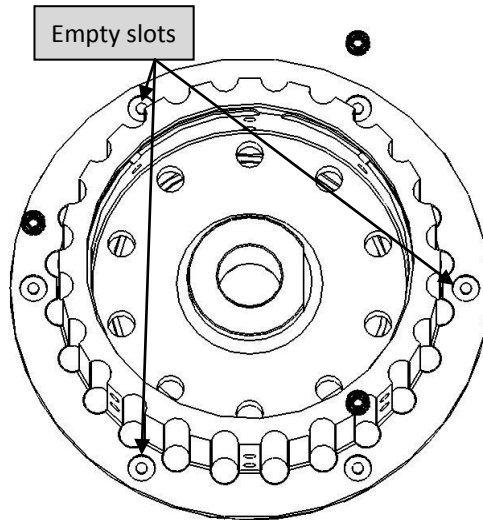

10. '99-'03 250/300/380 models **ONLY** (all others skip to step 11): Install the Rekluse Center Clutch with the OEM thrust washer AND Rekluse thrust washer behind it on top of the basket. Skip to step 12.

11. Install the Rekluse Center Clutch with the OEM thrust washer behind it on top of the basket.
12. Install the included Rekluse external tab lock washer over the main-shaft on top of the Rekluse center clutch.
13. Bend middle tab down aligned with flat side of the Rekluse Center Clutch.
14. Torque the center clutch nut to the specified torque found in the manufacturer's service manual.

**WARNING:** DO NOT over-torque the center clutch nut on the 450/505SXF.

15. Using a pair of adjustable pliers, bend remaining two tabs of external tab washer up against the nut securing it.



## INSTALLING THE CLUTCH PACK

16. The 8 Rekluse steel drive plates (7 for 125/200) packaged with the Rekluse Center Clutch come pre-measured and are the 8 steel drive plates you will start with.
17. **With the anti-squeal kit, remove 1 of the thicker steel plates and replace with thinner (.030" for 125/200 2-stroke and 250 4-stroke, .040" for all others) plate included with anti-squeal kit.**  
Install 1 Rekluse steel drive plate onto the Rekluse Center Clutch.
18. Install the stock friction disks with a Rekluse steel drive plate between each one. **See charts below for specific model configuration.**

**NOTE:** KTM 250/300 2-Strokes, 450/505 SXF/XC-F, and KTM 450/530 R's have 9 friction disks stock; with the Rekluse clutch you will use only 8 so you will have 1 left over.

**KTM 450/530 R, Husaberg 450/570 owners:** Remove the bottom most, Narrow Friction Disk, and use the 8 regular frictions with the z-Start PRO. Also, do-not install the clutch boss spring (2 metal rings at bottom of clutch pack) with the z-Start PRO.

Top of Pack

## KTM 125/200

**Stock Friction disk**

Rekluse Steel Drive Plate

**Stock Friction disk**

Rekluse .030" Steel Drive Plate (in anti-squeal kit)

**Stock Friction disk**

Rekluse Steel Drive Plate

**Stock Friction disk**

Rekluse Steel Drive Plate

**Stock Friction disk**

Rekluse Steel Drive Plate

**Stock Friction disk**

Rekluse Steel Drive Plate

**Stock Friction disk**

Rekluse Steel Drive Plate

Last Plate In



First Plate In

Bottom of pack

Top of Pack

## All Other Models

**Stock Friction disk**

Rekluse Steel Drive Plate

**Stock Friction disk**

Rekluse .040" Steel Drive Plate (.030" for 250 4-strokes, in anti-squeal kit)

**Stock Friction disk**

Rekluse Steel Drive Plate

**Stock Friction disk**

Rekluse Steel Drive Plate

**Stock Friction disk**

Rekluse Steel Drive Plate

**Stock Friction disk**

Rekluse Steel Drive Plate

**Stock Friction disk**

Rekluse Steel Drive Plate

**Stock Friction disk**

Rekluse Steel Drive Plate

Last Plate In



First Plate In

Bottom of pack

# INSTALLING THE Z-START PRO CLUTCH

19. Insert the 3 small belleville washers, concave side up, into the 3 slots at the top of the center clutch ring. Initiate by hand, then use a small screwdriver to slide the 3 retaining washers out to limit top drive plate travel. Failure to fully seat these washers will result in clutch damage. See diagrams below.

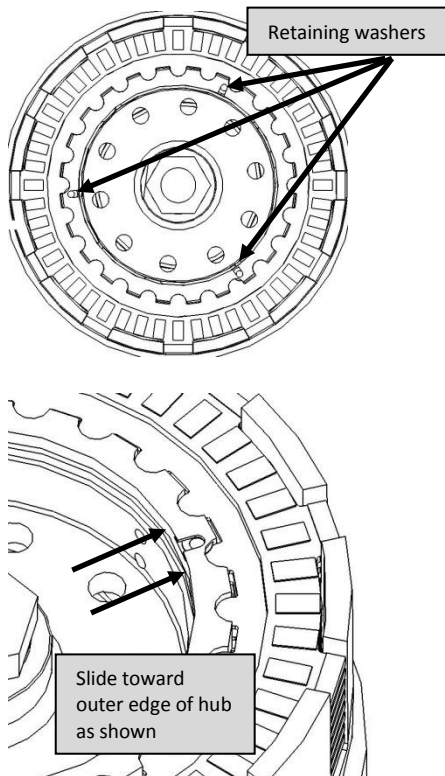

20. Place lower assembly into Rekluse center clutch hub. You must align the three cut-outs in the lower assembly with the corresponding tabs in the center clutch. **Note:** some models only have two cut-outs.

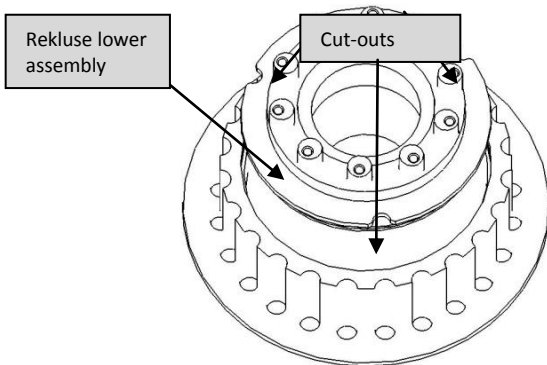

21. Using a pair of mechanics gloves (the edges of the ring can be sharp and may cut you), install the retaining ring into the Rekluse Center Clutch ring groove.

You must ensure the retaining ring is snapped into the groove. Start the square end of the ring and thread the ring into the groove as shown, ensuring that the scalloped end of the ring is *clockwise in relation to the square end*.

**WARNING:** Scalloped end of ring **MUST** be oriented as shown below.



Threading retaining ring into groove



Use a screwdriver to ensure the ring is seated by sliding along the ring's inner diameter.

**WARNING:** It is **CRITICAL** that the retaining ring is fully seated using a screwdriver, or clutch damage **WILL** occur.

22. Install OEM clutch throw-out with bearing and washer on top into the transmission shaft. Ensure the needle bearing and thrust washer are placed on top of throw-out.

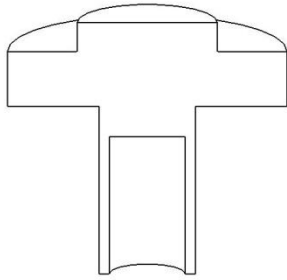

**NOTE:** 250SXF/XCF/XCF-W skip to step 24.  
 450/505 SXF skip to Step 25.  
 400/450/530 R skip to Step 26.  
 250/300 2-strokes skip to Step 27.

23. **KTM 125/200 only:** Install the Rekluse throw-out spacer on top of the throw-out.

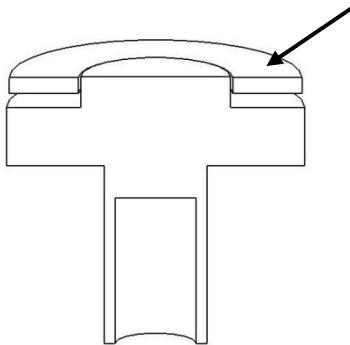

24. **KTM 250SXF/XCF/XCF-W only:** Install the Rekluse throw-out spacer followed by the circular oil dam over the stock throw-out.

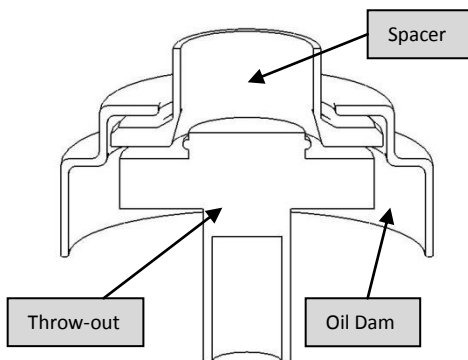

25. **KTM 450/505 SXF/XC-F only:** Install the 2 Belleville spring washers concave out on top of the stock throw-out. **Note:** see tuning chart for more information.

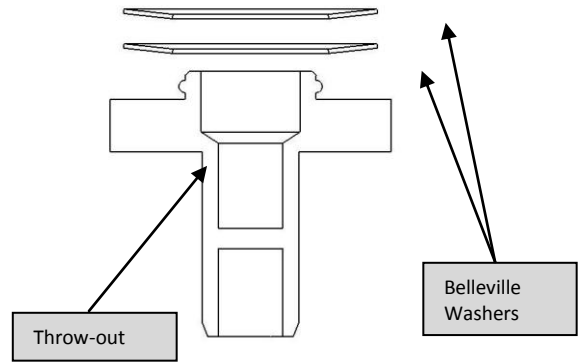

26. **KTM 400/450/530 XCR-W, EXC-R, Husaberg 450/570 FE only:** Install the 2 Belleville spring washers concave out on top of the stock throw-out followed by the Rekluse throw-out spacer. **Note:** see tuning chart for more information.

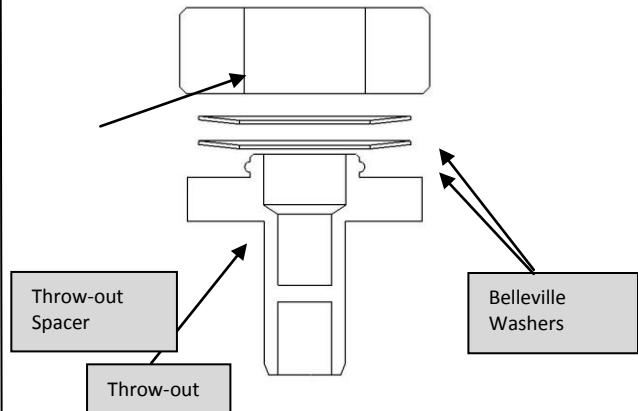

27. **KTM 250/300 2-strokes only:** The Throw-out spacer is a .030" thick washer that needs to be snapped over the clip on top of the OEM throw-out. See following pictures.





Rekluse washer snapped down into place over the throw-out clip

clutch pressure, so the 10 rotating hub posts index into the 10 pressure plate holes.

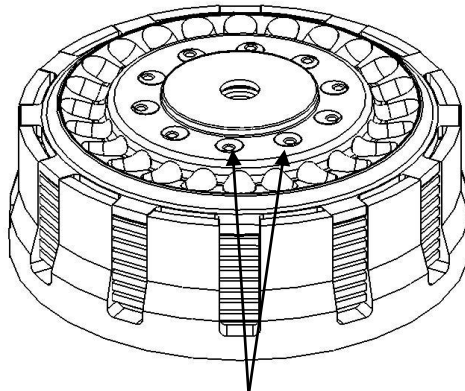

Rotating hub posts indexed into pressure plate holes

28. Read the Setup and Tuning Guide to determine desired spring setting.
29. Install the C200 wave spring (chosen based on your desired setup from the tuning sheet for your bike) on top of rotating hub into the locating pocket.

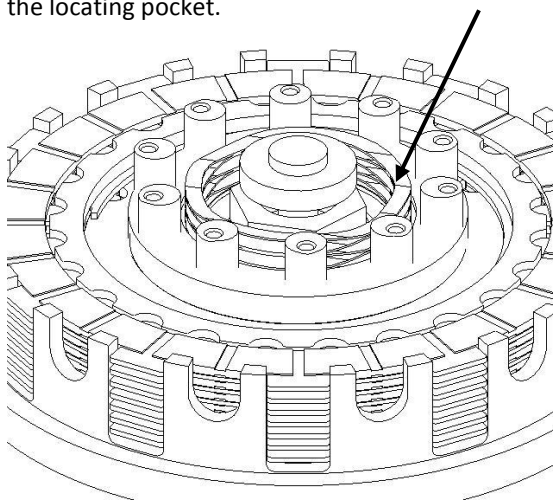

34. While holding down the pressure plate so it is indexed with the basket and 10 rotating hub posts properly, place the Rekluse top plate over the Rekluse pressure plate and thread in 2 torx head screws 180° across from one another. Lightly tighten the 2 screws to secure the Rekluse top plate.



30. Place a small amount of oil into the ball grooves of the Rekluse Pressure Plate.
31. Away from the bike, install the steel balls into the pressure plate ball grooves. See Tuning Guide for desired configuration.
32. Place the Rekluse pressure plate, with balls, over the lower assembly. Line the 10 holes in the pressure plate up with the 10 rotating hub posts. Also, line the outer tabs of the pressure plate up with the basket slots.

If your basket has 2 sets of slots, make sure you index the Rekluse pressure plate tabs into the main/deep slots.

33. Push and hold the pressure plate down, overcoming the wave spring and hydraulic

## DETERMINE THE INSTALLED GAP OF THE Z-START PRO CLUTCH

**Note:** Installed gap is measured using two no-go wire gauges. With the anti-squeal kit, you must use the included .040" gauges.

If gauges **do not** slide between Rekluse pressure plate and **the pads** of the top friction disk, your **installed gap is correct**.

If gauges **do** slide between the Rekluse pressure plate and **the pads** of the top friction disk, you **need to adjust your installed gap** according to step 36.

35. Attempt to slide the legs of the 2 included .040" *no-go* wire gauges (included in the anti-squeal kit) **between the Rekluse pressure plate and the friction pads** of the top friction disk 180° apart.

If clutch pack wear exists, gauges will slide in with slight resistance. Do not force the gauges in, if the gauges **do not** slide in smoothly then the Installed Gap is good and you can move on to Step 37.

**NOTE:** The larger .050" gauges are used for bikes without the anti-squeal kit.

**WARNING:** If larger .050" gauges are used, improper Installed Gap will result and clutch damage will occur.

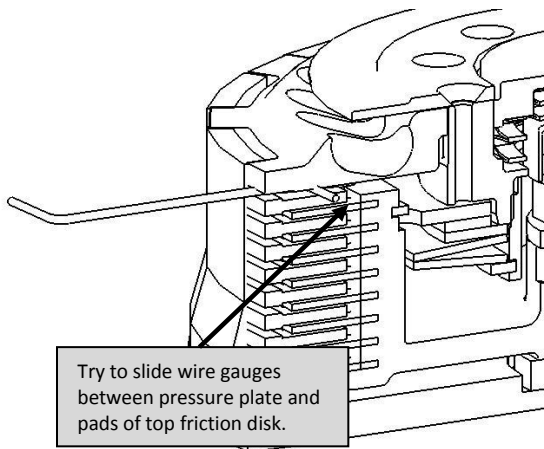
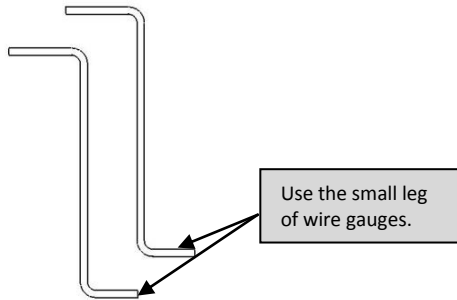

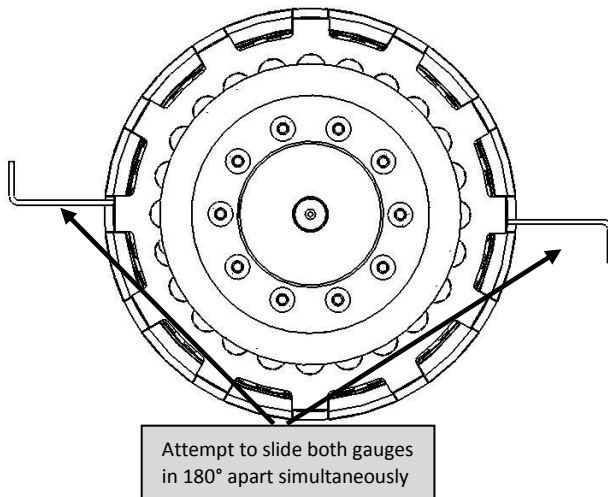

36. If the wire gauges slide in smoothly, the clutch pack needs adjustment. Swap the thick Rekluse adjustment drive plate for the top drive plate. Repeat step 35.

**Note:** If your bike is using the anti-squeal kit and you're adjusting first time for wear, replace .030" plate with .040" plate for small bore bikes and replace .040" plate with .048" plate for big bore bikes. For further adjustment, see next note.

**Note:** The adjustment drive plate is .060" for small bore bikes and .065" for big bore bikes. Once this drive plate has been used, and the clutch wears enough so the wire gauges slide in again, the friction disks need to be replaced.

37. Install the remaining 8 torx head screws using blue Loctite 243 and torque to 25 in-lbs (2.1 ft.-lbs.).
38. Remove the 2 screws originally installed without Loctite, apply Loctite and torque.
39. Re-install the clutch cover with thicker Rekluse Gasket.

**For the KTM 125/200 use both of the provided gaskets.**

Lightly tighten all of the cover bolts before full torque is applied, or you may break the cover.

**WARNING:** Thicker Rekluse gasket must be used or you will have clutch cover interference.

**Note:** Be sure to review the included Break-in and Maintenance Guide for clutch pack wear adjustments.

**WARNING:** After a 20 minute break-in period, the clutch plates will seat in and you must re-measure the Installed Gap to guarantee the Installed Gap is within the prescribed range—make drive plate adjustments if necessary. Clutch break-in re-measurement of the Installed Gap is necessary whenever new clutch plates are installed.

40. Refer to the "Safety Warnings" and "Break-in Tuning and Maintenance Guide" before operating the z-Start Pro clutch.

## APPENDIX A – CENTER CLUTCH REMOVAL TIP SHEET

The following covers 3 methods for removing the OEM center clutch from your motorcycle or ATV. **At no time should you ever pry against the standoffs of the OEM center clutch because they are easily broken.**

**Note:** If your bike has an external tab lock washer, use a flat blade screwdriver to pry the tabs away from the nut. Next use a hammer and punch to lightly tap the tabs flat.

**1. Pneumatic or electric impact gun:**

Place the bike in gear and remove the nut

**2. Clutch Holding Tool:**

Example: Motion Pro # 08-0008

Use the clutch holding tool to hold the center clutch while using a wrench to remove the center clutch nut.

**3. Holding the Rear Brake:**

Place the bike in 4<sup>th</sup> or 5<sup>th</sup> gear (a higher gear gives you more mechanical advantage). Apply the rear brake firmly and hold firmly while using a wrench to remove the center clutch nut. A second set of hands is helpful.