

# REKLUSE



## REKLUSE MOTOR SPORTS

---

The z-Start Pro Clutch

### INSTALLATION GUIDE

**SUZUKI**

**RMZ450**

**LTR450**

191-865  
Manual Revision: 032508

©2002 Rekluse Motor Sports  
Rekluse Motor Sports, Inc.  
110 E. 43rd Street  
Boise, Idaho 83714  
208-426-0659  
support@rekluse.com

# TABLE OF CONTENTS

<b>z-START PRO CROSS-SECTION VIEW</b>	<b>3</b>
<b>INCLUDED PARTS</b>	<b>3</b>
<b>REQUIRED TOOLS</b>	<b>3</b>
<b>BIKE PREPARATION AND DISASSEMBLY</b>	<b>4</b>
<b>CLUTCH BASKET INSPECTION</b>	<b>5</b>
<b>INSTALLING THE z-START PRO CENTER CLUTCH</b>	<b>6</b>
<b>INSTALLING THE CLUTCH PACK</b>	<b>7</b>
<b>INSTALLING THE z-START PRO CLUTCH</b>	<b>8</b>
<b>DETERMINE THE INSTALLED GAP OF THE z-START PRO CLUTCH</b>	<b>11</b>
<b>SETTING CLUTCH CABLE SLACK</b>	<b>13</b>
<b>APPENDIX A – CENTER CLUTCH REMOVAL TIP SHEET</b>	<b>14</b>

## Z-START PRO CROSS-SECTION VIEW

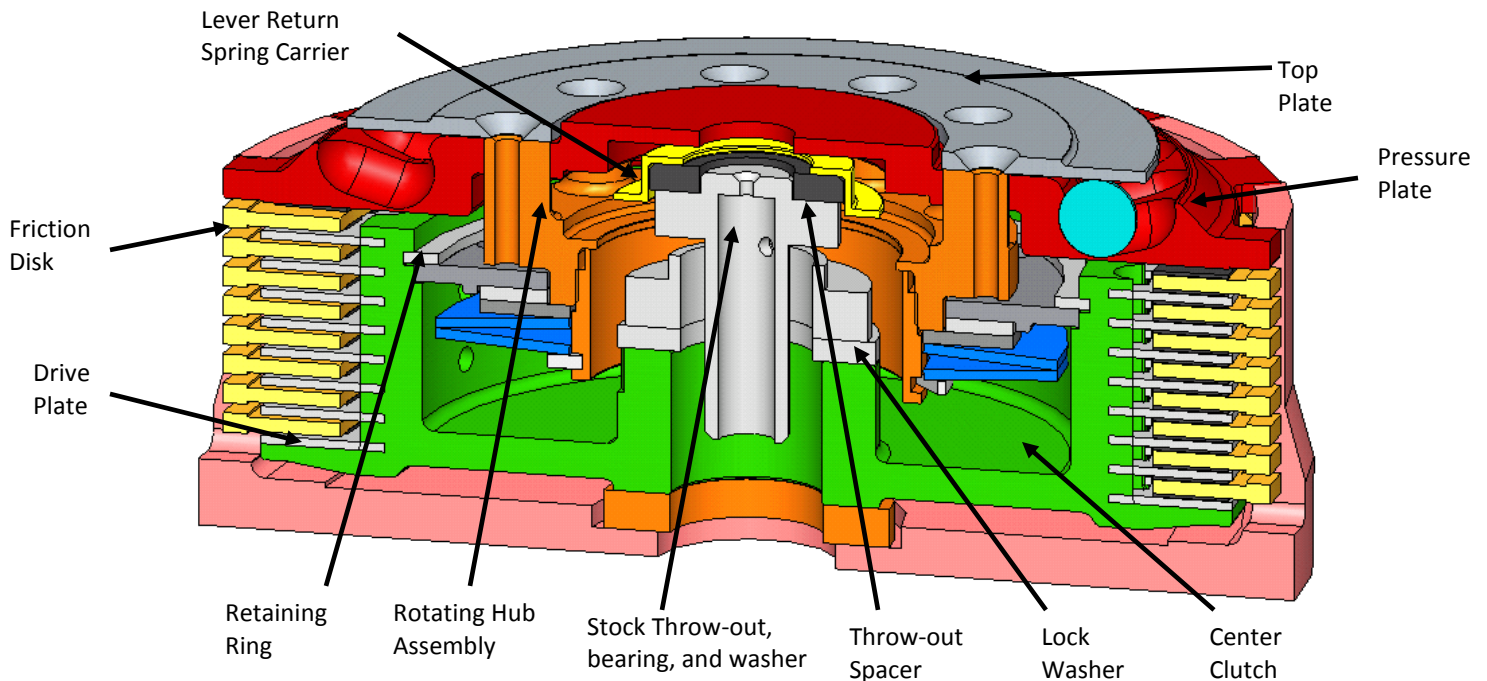

## INCLUDED PARTS

### Item

- Top Plate
- Pressure Plate
- Rekluse Center Clutch
- Retaining Ring
- (8) RMS Measured Drive Plates
- (1) RMS .065" Plate (Adjustment Plate)
- Rotating Hub Assembly
- External Tab Lock Washer
- Lever Return Spring Carrier
- Rekluse Throw-out Spacer
- Rekluse Throw-out (LTR450 Only)

### Item

- (27) 7/16" Chrome Steel Ball Bearings (big bore bikes)
- (3) 7/16" Tungsten Carbide Ball Bearings (LTR 450 Only)
- (10) M4x12 Torx Head Screws
- Wave Springs – See Included Tuning Chart for your Model
- T-20 Torx Bit
- Blue Loctite 243
- Rekluse Clutch Cover Gasket
- Rekluse Wire Gauges
- Quick Splice

## REQUIRED TOOLS

- 8mm socket
- 10mm socket
- 27mm or 30mm socket (for center clutch nut)
- T-20 Torx bit (supplied)
- Impact Wrench

## BIKE PREPARATION AND DISASSEMBLY

1. Disconnect the clutch cable at the clutch perch.
2. Shut off fuel at petcock. Lay bike on left side. **CAUTION:** fuel may drain from carburetor; to prevent fire hazard, place a suitable container beneath bike to catch fuel.
3. Remove clutch cover.
4. Remove bolts and springs from OEM pressure plate.
5. Remove OEM pressure plate.
6. Remove OEM clutch throw out and set aside. It will be re-installed.

**Note:** LTR450 uses the included Rekluse Throw-out in place of the stock one.

7. Remove the clutch pack (friction disks and drive plates). Separate the friction disks from the pack as they will be re-installed.

**Note:** The 2-piece clutch boss spring located at the bottom of the clutch pack will not be re-installed.

8. Remove the OEM center clutch hub following the steps outlined in the vehicle manufacturer's service manual. Also, see the center clutch removal tip sheet (Appendix A) for further assistance.
9. Retain OEM thrust washer located between OEM clutch basket and OEM center clutch hub.

**NOTE:** thrust washer may be stuck to bottom of OEM center clutch hub.

# CLUTCH BASKET INSPECTION

**Note:** The following outlines Clutch Basket Dampener Failure. Some Clutch baskets will last a season, and some last only hours. If the dampeners go unchecked clutch damage will result. After inspecting basket, continue with the z-Start Pro installation.

## Clutch Basket Dampener Operation

Most OEM Clutches use elastomer dampeners to protect the clutch from shock loading applied to the basket by the drive train and/or engine during normal operating conditions. The dampeners are located between the clutch basket body and the ring gear. The dampeners take up the slack between the ring gear and clutch basket so that under normal loading they rotate as one. Under extreme loading the dampeners provide a cushion so the ring gear and basket can float independently and keep shock loads from being transferred to the clutch.

As the dampeners wear, the system gains slack and shock loads start getting transferred to the clutch. This creates a hammering effect between the clutch basket and ring gear. The hammering transfers to the clutch plates and causes the plates to wear away at the clutch basket and center clutch hub. If the dampeners continue to go unchecked, the hammering progresses until the clutch fails.

## Checking Your Clutch Basket for Dampener Failure

Prior to installing the z-Start Pro, it is recommended that you check the condition of your Clutch Basket and Center Clutch Hub.

An indication of failing clutch basket dampeners is grooving or notching of the Clutch Basket Ears—where the tabs of the friction discs index into the clutch basket.

**See the following picture.**

Another indication of failing dampeners is notching of the center clutch hub where the steel drive plates index to it.

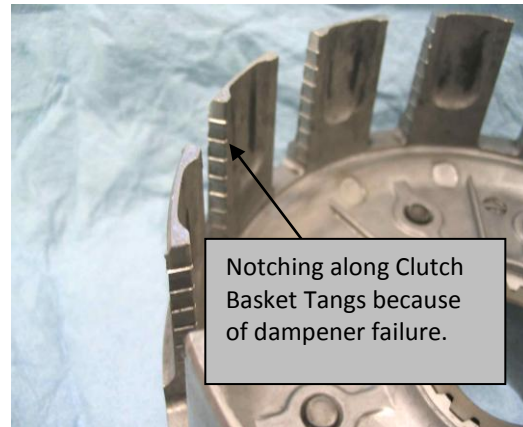

## Maintaining Clutch Basket Dampeners

Unfortunately the OEM clutch basket does not provide a means to maintain the dampeners. After the dampeners wear out, the clutch basket must be replaced. The choice is either an OEM clutch basket, or an aftermarket basket. The advantage of an aftermarket basket is that the dampeners are serviceable. Rekluse offers aftermarket clutch baskets specially designed for greater performance with the z-Start Pro.

**WARNING:** Installing the z-Start into a worn out clutch basket can greatly reduce clutch performance, and damage the z-Start Pressure Plate.

## INSTALLING THE Z-START PRO CENTER CLUTCH

10. Install the Rekluse Center Clutch with the OEM thrust washer behind it on top of the basket.
11. Install the included Rekluse external tab lock washer over the main-shaft on top of the Rekluse center clutch.
12. Torque the center clutch nut to the specified torque found in the manufacturer's service manual.
13. Using a pair of adjustable pliers, bend remaining two tabs of external tab washer up against the nut to secure it. **See photo below.**



## INSTALLING THE CLUTCH PACK

14. The 8 Rekluse steel drive plates packaged with the Rekluse Center Clutch come pre-measured and are the 8 steel drive plates you will start with.

Install 1 Rekluse steel drive plate onto the Rekluse Center Clutch.

**Note:** A Rekluse steel drive plate must be the first clutch plate installed.

15. Install the stock friction disks with a Rekluse steel drive plate between each one.  
**See following chart:**

**Warning:** Do not install the OEM 2-piece clutch boss spring (located at the base of the stock center clutch).

*Top of Pack*

**Stock Friction disk**  
Rekluse Steel Drive Plate  
**Stock Friction disk**  
Rekluse Steel Drive Plate  
**Stock Friction disk**  
Rekluse Steel Drive Plate  
**Stock Friction disk**  
Rekluse Steel Drive Plate  
**Stock Friction disk**  
Rekluse Steel Drive Plate  
**Stock Friction disk**  
Rekluse Steel Drive Plate  
**Stock Friction disk**  
Rekluse Steel Drive Plate  
**Stock Friction disk**  
Rekluse Steel Drive Plate

**Last Plate In**



**First Plate In**

*Bottom of pack*

## INSTALLING THE Z-START PRO CLUTCH

16. Place lower assembly into Rekluse center clutch hub. You must align the three cut-outs in the lower assembly with the corresponding tabs in the center clutch. **Note:** some models only have two cut-outs.

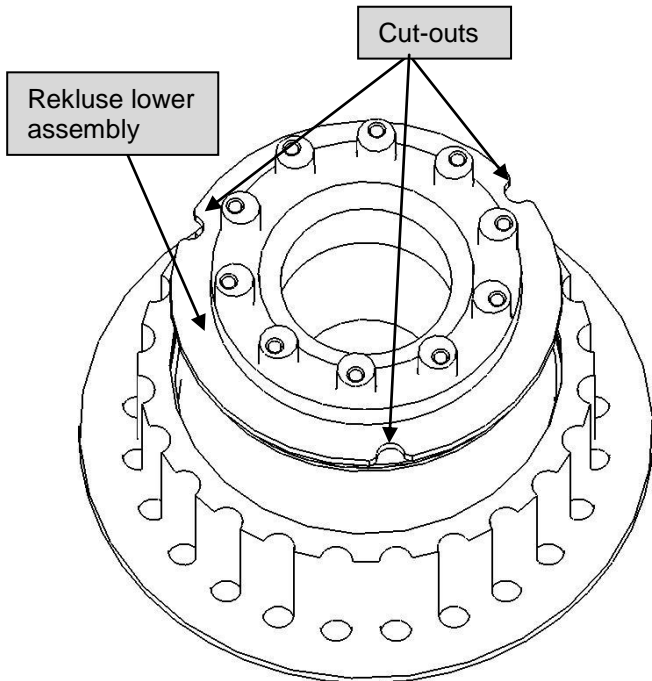

17. Using a pair of mechanics gloves (the edges of the ring can be sharp and may cut you), install the retaining ring into the Rekluse Center Clutch ring groove.

You must ensure the retaining ring is snapped into the groove. Start the square end of the ring and thread the ring into the groove as shown, ensuring that the scalloped end of the ring is clockwise in relation to the square end.

**WARNING: Scalloped end of ring MUST be oriented as shown above-right.**

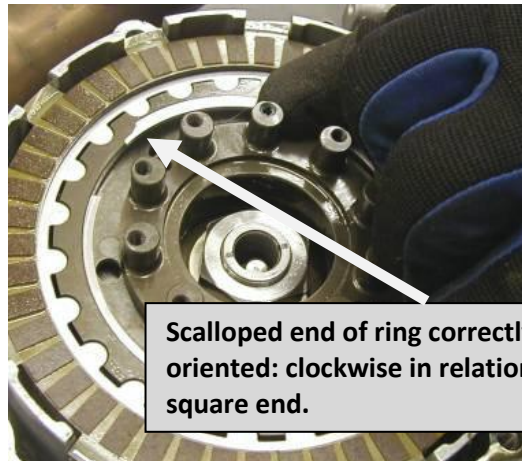

Scalloped end of ring correctly oriented: clockwise in relation to square end.

Threading retaining ring into groove



Use a screwdriver to ensure the ring is seated by sliding along the ring's inner diameter.

**WARNING: It is CRITICAL that the retaining ring is fully seated using a screwdriver, or clutch damage WILL occur.**

- 18. LTR450 only (RMZ450 skip to Step 19):**  
Install the 7/32" ball bearing with Rekluse throw-out on top of the OEM throw-out rod. The 7/32" ball must be between the OEM rod and the Rekluse throw-out.

Next place the needle bearing and flat washer on top of the Rekluse throw-out followed by the Rekluse spacer and Spring Carrier.

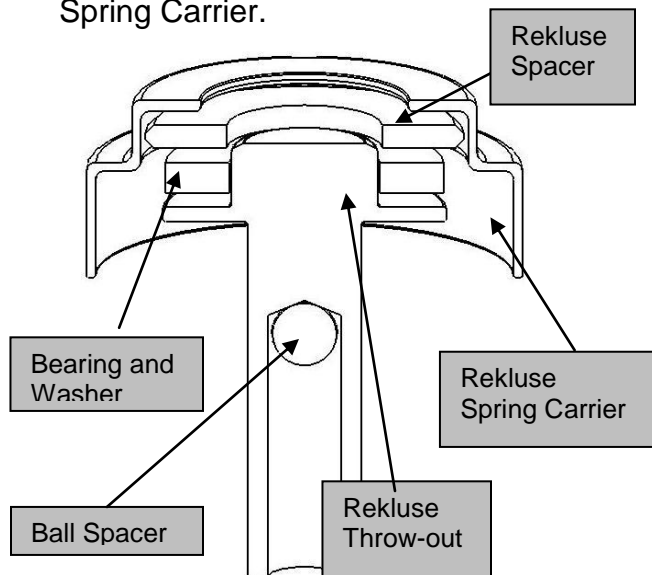

- 19. RMZ 450 only (LTR 450 skip to Step 20):**  
Install OEM clutch throw-out  
Next place the Rekluse Spacer on top of the OEM throw-out followed by the Spring Carrier.

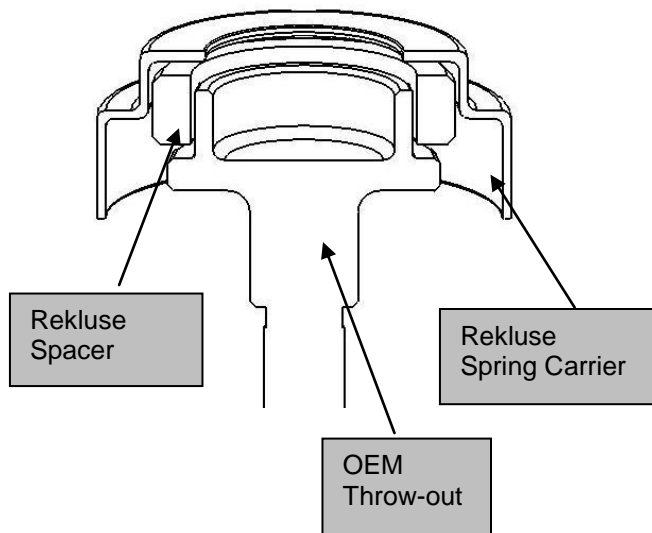

**Note:** RMZ450 customers: the RMZ450 does not have a needle bearing or washer on it; place throw-out spacer on top of the stock throw-out.

**Note:** Diagrams are representative. Your parts may differ slightly.

- 20.** Read the Setup and Tuning Guide to determine desired spring setting.  
**21.** Install the C150 wave spring on top of clutch lever return spring carrier.

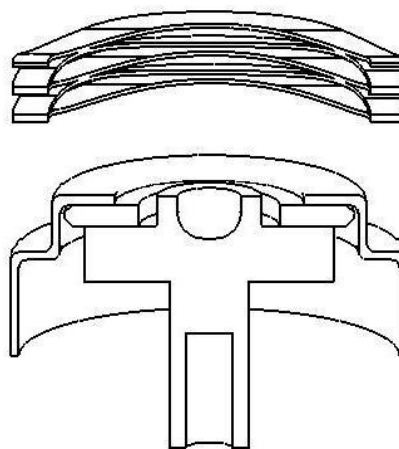

- 22.** Install the C200 wave spring (if used by chosen configuration) on top of rotating hub into the locating pocket.

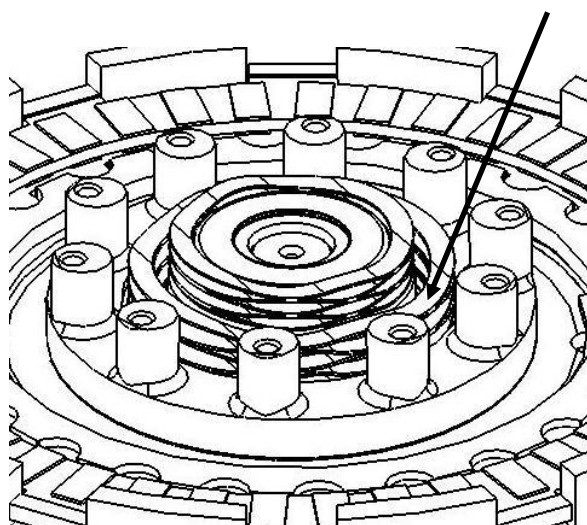

**23.** Place a small amount of oil into the ball grooves of the Rekluse Pressure Plate.

**24.** Away from the bike, install the steel balls into the pressure plate ball grooves. Refer to Setup and Tuning Guide for desired number of balls and proper distribution pattern.

If your basket has 2 sets of slots, make sure you index the Rekluse pressure plate tabs into the main/deep slots.

**25.** Push and hold the pressure plate down, overcoming the wave spring(s) so the 10 rotating hub posts index into the 10 pressure plate holes.

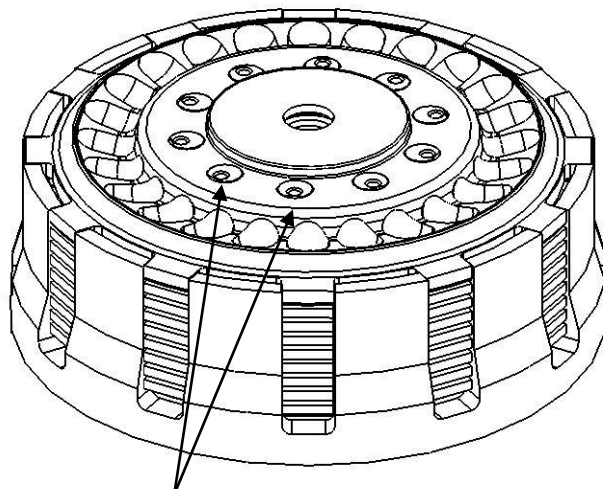

Rotating hub posts indexed into pressure plate holes.

**26.** While holding down the pressure plate so it is indexed with the basket and 10 rotating hub posts properly, place the Rekluse top plate over the Rekluse pressure plate and thread in 2 torx head screws 180° across from one another. Lightly tighten the 2 screws to secure the Rekluse top plate.



## DETERMINE THE INSTALLED GAP OF THE Z-START PRO CLUTCH

**Note:** Installed gap is measured using two no-go wire gauges. Therefore, if gauges **do not** slide between Rekluse pressure plate and **the pads** of the top friction disk, your **installed gap is correct**.

If gauges **do** slide between the Rekluse pressure plate and **the pads** of the top friction disk, you **need to adjust your installed gap** according to step 31.

**27.** Verify that top-most friction disk moves up and down freely between the Pressure Plate and top-most steel drive plate by pulling up and down on top-most friction disk. If no “float” exists, top-most **steel drive plate** has become disoriented during previous step and needs to be re-installed.

**28.** Attempt to slide the shorter legs of the 2 included 0.050” no-go wire gauges **between the Rekluse pressure plate and the friction pads** of the top friction disk 180° apart.

If clutch pack wear exists, gauges will slide in with slight resistance. Do not force the gauges in; if the gauges **do not** slide in smoothly then the Installed Gap is good and you can move on to step 31.

**29.** If the wire gauges slide in **smoothly**, the clutch pack needs adjustment. Swap the thick Rekluse adjustment drive plate for the top drive plate. Repeat step 30.

**Note:** Once the drive plate has been used and the clutch wears enough so the wire gauges slide in again, the friction disks need to be replaced.

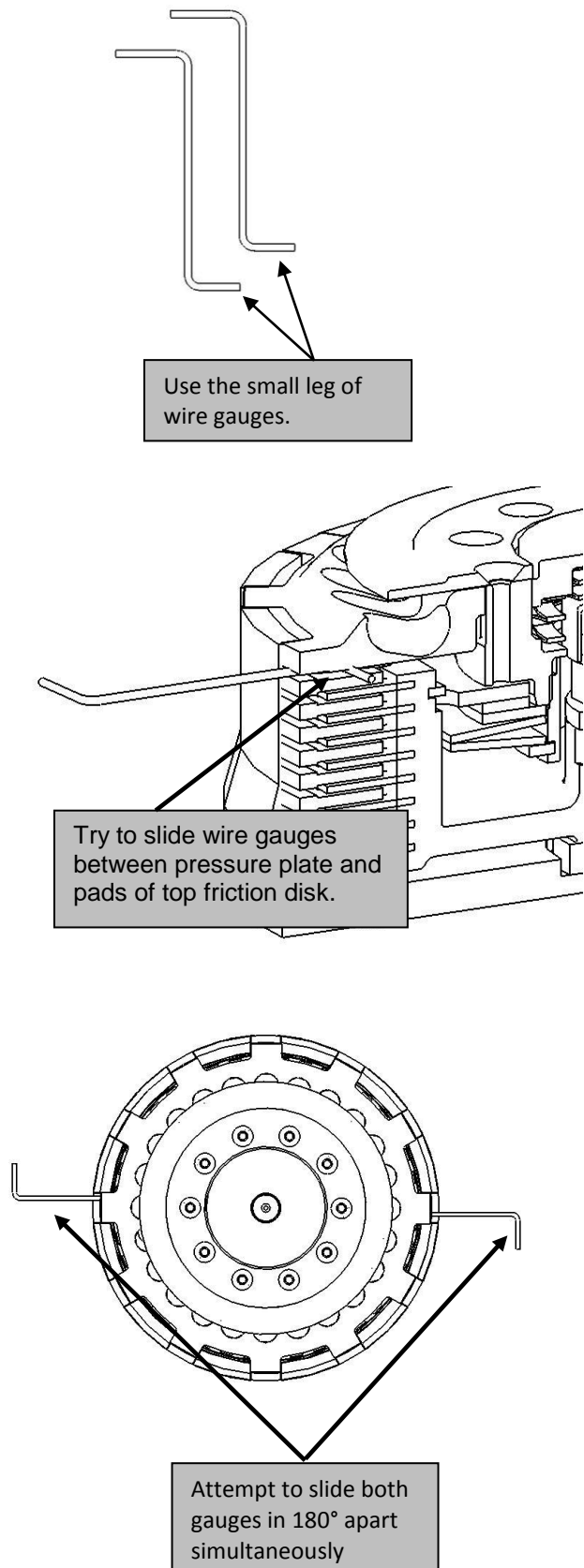

30. Install the remaining 8 torx head screws using blue Loctite 243 and torque to 25 in-lbs (2 ft-lbs.).
31. Remove the 2 screws originally installed without Loctite, apply Loctite and torque.
32. Re-install the clutch cover with thicker Rekluse Gasket. Lightly tighten all of the cover bolts before full torque is applied, or you may break the cover.

**Warning:** Thick Rekluse gasket must be used or clutch damage will result.

33. Reconnect the clutch cable to the lever and stand the bike upright.

**IMPORTANT: SEE NEXT PAGE OF INSTRUCTIONS FOR PROPER CABLE SLACK SETTING**

Adjust the cable slack for the z-Start Pro (**SEE NEXT PAGE**).

## SETTING CLUTCH CABLE SLACK

**IMPORTANT:** Cable slack adjustment is **critical**. The cable slack must be adjusted properly and maintained frequently. Failure to do so will result in clutch failure. Adjusting cable slack is different with a z-Start Pro Clutch installed. Cable slack adjustment requires starting the motor in neutral and revving to a minimum of 4500 RPMs (approximately 1/2-throttle) while checking for lever free play. **There must be clutch lever free play while holding a minimum of 4500 RPMs.**

**If there is not enough cable slack, the clutch will slip excessively causing the clutch to fail.**

Too much cable slack reduces the ability to disengage the clutch at higher RPMs.

**WARNING:** *Ensure the bike is in neutral* or it could lunge forward unexpectedly when revving the engine.

**Place the bike into neutral and start the engine.** While holding a minimum of 4500 RPMs, check for 1/2" (1cm) of play at the end of the clutch lever before you feel significant resistance. Adjust cable slack accordingly using stock cable slack adjuster(s).

In other words, when revving the engine, clutch lever free play should feel like stock.

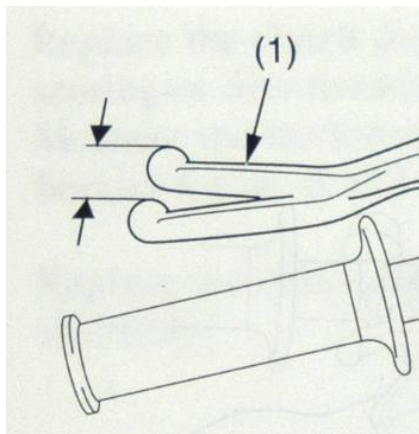

**Tip:** Use one finger with light pull when checking for lever free play. This will make it easier to distinguish between the light resistance of the lever return spring and the significant resistance felt when disengaging the Rekluse pressure plate.

**Note:** Be sure to review the included Break-in and Maintenance Guide for clutch pack wear adjustments.

**WARNING:** After a 20 minute break-in period, the clutch plates will seat in and you must re-measure the Installed Gap to guarantee the Installed Gap is within the prescribed range—make drive plate adjustments if necessary. Clutch break-in re-measurement of the Installed Gap is necessary whenever new clutch plates are installed.

Refer to the “Safety Warnings” and “Break-in Tuning and Maintenance Guide” before operating the z-Start Pro clutch.

## APPENDIX A – CENTER CLUTCH REMOVAL TIP SHEET

The following covers 3 methods for removing the OEM center clutch from your motorcycle or ATV. **At no time should you ever pry against the standoffs of the OEM center clutch because they are easily broken.**

**Note:** If your bike has an external tab lock washer, use a flat blade screwdriver to pry the tabs away from the nut. Next use a hammer and punch to lightly tap the tabs flat.

- 1. Pneumatic or electric impact gun:**  
Place the bike in gear and remove the nut
- 2. Clutch Holding Tool:**  
Example: Motion Pro # 08-0008  
Use the clutch holding tool to hold the center clutch while using a wrench to remove the center clutch nut.
- 3. Holding the Rear Brake:**  
Place the bike in 4<sup>th</sup> or 5<sup>th</sup> gear (a higher gear gives you more mechanical advantage). Apply the rear brake firmly and hold firmly while using a wrench to remove the center clutch nut. A second set of hands is helpful.